

**GAI-TRONICS® CORPORATION**

A HUBBELL COMPANY

# Model 13352, 13362 and 13372 Addressable Amplified Speakers Installation and Operation Manual

---



**Patent Pending**





**GAI-TRONICS® CORPORATION**  
A HUBBELL COMPANY

# Model 13352, 13362 and 13372 Addressable Amplified Speakers Installation and Operation Manual

---

## Table of Contents

<b><i>Foreword</i></b> .....	<b>3</b>
<b>Scope of Manual</b> .....	<b>3</b>
<b>Nomenclature</b> .....	<b>3</b>
<b>Ordering Replacement Parts</b> .....	<b>3</b>
<b>Service and Repair</b> .....	<b>3</b>
<b>Confidentiality Notice</b> .....	<b>4</b>
<b>FCC Licensing Information</b> .....	<b>4</b>
<b>Computer Software Copyrights</b> .....	<b>5</b>
<b>Warranty</b> .....	<b>5</b>
<b>Safety and General Information</b> .....	<b>6</b>
User Instructions .....	6
Exposure to Radio Frequency Energy.....	6
Antenna Care .....	7
Electromagnetic Interference/Compatibility.....	7
Hospitals or Health Care Facilities.....	7
Medical Devices - Pacemakers.....	7
Blasting Caps and Areas.....	7
<b>Safe Handling of CMOS Integrated Circuit Devices</b> .....	<b>8</b>
<b>Replacement Parts and Kits</b> .....	<b>9</b>
<b>Programming Software and Cable</b> .....	<b>9</b>
<b>Performance Specifications</b> .....	<b>10</b>
<b><i>Introduction</i></b> .....	<b><i>12</i></b>
<b><i>Functional Description</i></b> .....	<b><i>13</i></b>
<b>Generic Operation</b> .....	<b>13</b>
<b>Selective Operation</b> .....	<b>13</b>
DTMF Signaling .....	13
2-Tone Signaling.....	14
<b>Volume Adjustments</b> .....	<b>14</b>

Remote Volume Adjustment .....	14
Local Volume Adjustment .....	14
<b><i>Field Installed Options</i></b> .....	<b>15</b>
<b>Model SPK200 Solar Interface Kit</b> .....	<b>15</b>
<b>Model XB001 External Long-Life Battery Kit</b> .....	<b>15</b>
<b>Model 190-002PS Power Supply Kit</b> .....	<b>16</b>
<b>Model BB133 Battery Back-up Kit</b> .....	<b>18</b>
<b>Model 12506-001 Remote Volume Control Assembly</b> .....	<b>18</b>
<b>PC Programming</b> .....	<b>18</b>
<b><i>Operation</i></b> .....	<b>19</b>
<b>Use Cases</b> .....	<b>19</b>
Generic Broadcast Activation.....	19
Selective Broadcast Activation .....	19
Remote Volume Adjustment (DTMF only).....	20
Selective Broadcast Operation, Wrong Activation Code Received .....	20
<b><i>Installation</i></b> .....	<b>21</b>
<b>Mechanical Receipt Inspection</b> .....	<b>21</b>
<b>Equipment Required</b> .....	<b>21</b>
<b>Cable Installation Safety Considerations</b> .....	<b>21</b>
<b>Mounting</b> .....	<b>22</b>
<b>Programming</b> .....	<b>23</b>
General Description .....	23
CARD Suite Software Installation.....	23
RF Module Programming Software Installation .....	23
Preparing to Program.....	23
<b>Programming the Addressable Speaker PCBA (All Models)</b> .....	<b>24</b>
Settings and Adjustments.....	25
<b>Programming the RF Module (19101-024 Programming Kit) - Models 13362/13372 Only</b> .....	<b>26</b>
Wiring.....	27
<b>12506-001 Remote Volume Control Wiring Instructions</b> .....	<b>28</b>
<b><i>Hardware Configuration</i></b> .....	<b>31</b>
Jumpers .....	31
Fuse Replacement.....	31
LEDs.....	31
TB1 Wiring Connector .....	32
Radio Connector Pinout.....	33
Terminal Strip Designations .....	34
<b><i>Definitions and Acronyms</i></b> .....	<b>35</b>

# Model 13352, 13362, and 13372 Addressable Amplified Speakers Installation and Operation Manual

---

## Foreword

### Scope of Manual

This manual offers descriptive data and service information for the Addressable Amplified Speaker Assemblies.

### Nomenclature

The model number, located on the nameplate on the bottom, specifically identifies GAI-Tronics equipment. If additional options are ordered, the option will be identified on the circuit board.

### Ordering Replacement Parts

When ordering replacement parts or requesting equipment information, please include the complete identification number. This applies to all components, kits, and chassis. If the component part number is not known, the order should include the number of the chassis or kit of which it is a part and sufficient description of the desired component to identify it. Order parts from:

#### **Customer Service**

GAI-Tronics Corporation

400 E. Wyomissing Ave.

Mohnton, PA 19540

US: 800-492-1212

Outside US: 610-777-1374

### Service and Repair

Inoperative or malfunctioning equipment should be returned to the factory for repair. Please call **1-800-492-1212** or **610-777-1374** to obtain a Return Authorization number, published repair prices, and shipping instructions.

**NOTE:** A purchase order or credit card number is required prior to processing non-warranty repairs.

## Confidentiality Notice

This manual is provided solely as an operational, installation, and maintenance guide and contains sensitive business and technical information that is confidential and proprietary to GAI-Tronics. GAI-Tronics retains all intellectual property and other rights in or to the information contained herein, and such information may only be used in connection with the operation of your GAI-Tronics product or system. This manual may not be disclosed in any form, in whole or in part, directly or indirectly, to any third party.

## FCC Licensing Information

Your radio operates on General Mobile Radio Service (GMRS) frequencies and is subject to the Rules and Regulations of the Federal Communications Commission (FCC). The FCC requires that all operators using GMRS frequencies obtain a radio license before operating their equipment. To obtain the FCC forms, go to <http://wireless.fcc.gov/services/personal/generalmobile/index.html> to obtain Forms **605** and **159**, which include all forms and instructions.

Changes or modifications not approved by GAI-Tronics Corporation may void the user's authority granted by the FCC to operate this radio and should not be made. To comply with FCC requirements, transmitter adjustments should be made only by or under the supervision of a person certified as technically qualified to perform transmitter maintenance and repairs in the private land mobile and fixed services as certified by an organization representative of the user of those services. Replacement of any transmitter component (crystal, semiconductor, etc.) not authorized by the FCC equipment authorization for this radio could violate FCC rules.

**NOTE:** Use of this radio outside the country where it was intended to be distributed is subject to government regulations and may be prohibited.

Federal Communications Commission (FCC)

1-202-418-0177 1-800-418-FORM

1-800-418-3676

1-888-CALL-FCC

1-888-225-5322

Or: <http://www.fcc.gov>

## Computer Software Copyrights

This product contains copyrighted computer programs stored in semiconductor memory. These programs are copyrighted by GAI-Tronics Corporation and may not be reproduced in any form without express written permission from GAI-Tronics.

## Warranty

GAI-Tronics warrants for a period of one (1) year from the date of shipment, that any GAI-Tronics equipment supplied hereunder shall be free of defects in material and workmanship, shall comply with the then-current product specifications and product literature, and if applicable, shall be fit for the purpose specified in the agreed-upon quotation or proposal document. If (a) Seller's goods prove to be defective in workmanship and/or material under normal and proper usage, or unfit for the purpose specified and agreed upon, and (b) Buyer's claim is made within the warranty period set forth above, Buyer may return such goods to GAI-Tronics' nearest depot repair facility, freight prepaid, at which time they will be repaired or replaced, at Seller's option, without charge to Buyer. Repair or replacement shall be Buyer's sole and exclusive remedy, and the warranty period on any repaired or replacement equipment shall be one (1) year from the date the original equipment was shipped. In no event shall GAI-Tronics' warranty obligations with respect to equipment exceed 100% of the total cost of the equipment supplied hereunder. The applicability of any such third-party warranty will be determined solely by GAI-Tronics.

**Services.** Any services GAI-Tronics provides hereunder, whether directly or through subcontractors, shall be performed in accordance with the standard of care with which such services are normally provided in the industry. If the services fail to meet the applicable industry standard, GAI-Tronics will, for a period of one (1) year from the date of completion, re-perform such services at no cost to the Buyer. Re-performance of services shall be Buyer's sole and exclusive remedy, and in no event shall GAI-Tronics' warranty obligations with respect to services exceed 100% of the total cost of services provided hereunder.

**Limitations/Exclusions.** The warranty on any equipment supplied hereunder is subject to Customer's use in compliance with applicable FCC regulations and manufacturer specifications. The warranties herein shall not apply to, and GAI-Tronics shall not be responsible for, any damage to the goods or failure of the services supplied hereunder, to the extent caused by accident, misuse, abuse, neglect, system design, product modification, failure to follow instructions contained in the product manual, repair, or attempted repair by anyone not authorized by GAI-Tronics, improper installation, installation of parts that do not conform to the quality or specifications of the original parts or accessories, damage or loss occurred during shipment, or any unit which is not new when sold or upon which the serial number has been defaced, modified or removed. The warranty does not extend to damage incurred by natural causes including Force Majeure. The warranty does not cover microprocessors if failure is due to static damage or application of improper voltage. THE WARRANTIES AND REMEDIES CONTAINED HEREIN ARE IN LIEU OF AND EXCLUDE ALL OTHER WARRANTIES AND REMEDIES, WHETHER EXPRESS OR IMPLIED BY OPERATION OF LAW OR OTHERWISE, INCLUDING ANY WARRANTIES OF MERCHANTABILITY OR FITNESS FOR A PARTICULAR PURPOSE.

**Operational and Maintenance Procedures.** Buyer acknowledges that any improper use, maintenance, or modification of the equipment provided hereunder, or use of unqualified maintenance or service technicians will severely impair the operational effectiveness of the entire communication system. Buyer hereby agrees to indemnify, defend and hold GAI-Tronics harmless from and against any and all third party claims arising, in any manner, out of: (a) Buyer's neglect of the equipment; (b) Buyer's use of technicians not authorized by GAI-Tronics to service the equipment; or (c) Buyer's improper use or modification of the equipment or failure to follow the operational and maintenance procedures provided with the equipment.

**Limitation of Liability/Damages.** In no event (even should circumstances cause the exclusive warranties and remedies set forth in the Warranty section to fail of their essential purpose) shall either party be liable for any indirect, incidental, special or consequential damages (including, but not limited to, loss of use, loss of anticipated profits, or damages arising from delay) whether such claims are alleged to have arisen out of breach of warranty, breach of contract, strict or absolute liability in tort, or other act, error or omission, or from any other cause whatsoever, or any combination of the foregoing.

## Safety and General Information



Installation should only be performed by qualified service personnel in accordance with the National Electrical Code or applicable local codes.



**Power Sources** - Operate this unit only from the type of power source indicated on the label. If unsure of the type of power supply to use, contact qualified service personnel.

- For units intended to operate from battery power, refer to operating instructions.
- For units intended to operate with External Power Supplies, use only the recommended approved power supplies.
- For units intended to operate with a limited power source, this power source must comply with EN60950. Substitutions may damage the unit or cause fire or shock.

### Outdoor Product:

**Power Lines** - An outdoor system should not be located in the vicinity of overhead power lines, electric lights, or power circuits, or where it may contact such power lines or circuits, as this contact might be fatal. Refer to the National Electrical Code Article 800 regarding installation.

### User Instructions

This equipment has been tested and found to comply with the limits for a Class A digital device, pursuant to part 15 of the FCC Rules. These limits are designed to provide reasonable protection against harmful interference when the equipment is operated in a commercial environment. This equipment generates, uses, and can radiate radio frequency energy and, if not installed and used in accordance with the instruction manual, may cause harmful interference to radio communications. Operation of this equipment in a residential area is likely to cause harmful interference in which case the user will be required to correct the interference at his own expense.

### Exposure to Radio Frequency Energy

Your radio is designed to comply with the following standards and guidelines regarding exposure of human beings to radio frequency electromagnetic energy:

- FCC, Code of Federal Regulations; 47 CFR part 2 sub-part J
- American National Standards Institute (ANSI)/Institute of Electrical and Electronic Engineers (IEEE) C95.1-1992
- Institute of Electrical and Electronic Engineers (IEEE) C95.1-1999 Edition
- International Commission on Non-Ionizing Radiation Protection (ICNIRP) 1998
- Ministry of Health (Canada) Safety Code 6. Limits of Human Exposure to Radio Frequency Electromagnetic Fields in the Frequency Range from 3 kHz to 300 GHz, 1999

**Antenna Care**

Unauthorized antennas, modifications, or attachments could damage the radio and may violate FCC regulations.

**Do NOT hold the antenna when the radio is IN USE.** Holding the antenna affects the effective range.

**Approved Accessories**

Only use GAI-Tronics Corporation approved accessories. Please visit [www.gai-tronics.com](http://www.gai-tronics.com).

**Electromagnetic Interference/Compatibility**

Electronic equipment may be susceptible to electromagnetic interference. If you experience interference, visit the FCC website at <http://www.fcc.gov> for possible solutions.

## Operational Cautions

**Hospitals or Health Care Facilities**

To avoid electromagnetic interference and/or compatibility conflicts, turn off your radio in any facility where posted notices instruct you to do so. Hospital or health care facilities may be using equipment that is sensitive to external RF energy.

**Aircraft/Airports**

Airports may be using equipment that is sensitive to external RF energy. Any use of a radio must be in accordance with applicable regulations.

**Medical Devices - Pacemakers**

These recommendations are consistent with the independent research by, and recommendations of the U.S. Food and Drug Administration. Persons with pacemakers should:

- ALWAYS keep the radio more than six inches (15 cm) from their pacemaker when the radio is turned ON.
- Do NOT carry the radio in the breast pocket.
- Turn the radio OFF immediately if you have any reason to suspect that interference is taking place.

**Blasting Caps and Areas**

To avoid possible interference with blasting operations, turn off your radio when you are near electrical blasting caps, in a blasting area, or in areas posted: "Turn off two-way radio." Obey all signs and instructions.

## Safe Handling of CMOS Integrated Circuit Devices

Many of the integrated circuit devices used in communications equipment are of the Complementary Metal Oxide Semiconductor (CMOS) type. Because of their high open circuit impedance, CMOS integrated circuits are vulnerable to damage from static charges. Care must be taken handling, shipping, and servicing them and the assemblies in which they are used.

Even though protection devices are provided in CMOS integrated circuit inputs, the protection is effective only against overvoltage in the hundreds of volts range such as is encountered in an operating system. In a system, circuit elements distribute static charges and load the CMOS circuits, decreasing the chance of damage. However, CMOS circuits can be damaged by improper handling of the modules, even in a system.

To avoid damage to circuits, observe the following handling, shipping, and servicing precautions:

1. Prior to and while servicing a circuit module, particularly after moving within the service area, momentarily touch both hands to a bare metal, earth-grounded surface. This will discharge any static charge that may have accumulated on the person doing the servicing.  
**NOTE:** Wearing a conductive wrist strap will minimize static build-up during servicing.
2. Whenever possible, avoid touching any electrically conductive parts of the circuit module with your hands.
3. Power down the unit before installing or removing the circuit module.
4. When servicing a circuit module, avoid carpeted areas, dry environments, and certain types of clothing (silk, nylon, etc.) because they contribute to static build-up. Similarly, disconnect the test probe prior to removing the ground lead.
5. All electrically powered test equipment should be grounded. Apply the ground lead from the test equipment to the circuit module before connecting the test probe.
6. If a circuit module is removed from the system, it is desirable to lay it on a conductive surface (such as a sheet of aluminum foil) which is connected to ground through 100 k of resistance.
7. When soldering, be sure the soldering iron is grounded and has a grounded tip.
8. Prior to connecting jumpers, replacing circuit components, or touching CMOS pins (if this becomes necessary in the replacement of an integrated circuit device), be sure to discharge any static build-up as described in procedure 1. Since voltage differences can exist across the human body, it is recommended that only one hand be used if it is necessary to touch pins on the CMOS device and associated board wiring.
9. When replacing a CMOS integrated circuit device, leave the device in its conductive rail container or conductive foam until it is to be inserted into the printed circuit module.
10. All low impedance test equipment (such as pulse generators, etc.) should be connected to CMOS device inputs after power is applied to the CMOS circuitry. Similarly, such low impedance equipment should be disconnected before power is turned off.
11. Replacement modules shipped separately from the factory will be packaged in a conductive material. Any modules being transported from one area to another should be wrapped in a similar material (aluminum foil may be used). **Never use non-conductive material** for packaging these modules.

## Replacement Parts and Kits

Part No.	Description	13352	13362	13372
12544-003	Wiring Harness, Weatherproof Amplified Speaker	■	■	■
12544-006	Wiring Harness, 600-ohm	■		
13327-021	Speaker	■	■	■
19101-022	VHF Radio		■	
19101-023	UHF Radio			■
19502-007	VHF Antenna, 152–160 MHz		■	
19502-009	UHF Antenna, 432–468 MHz			■
61213-008	Cable, DB15 male to 8-pin		■	■
69840-001	PCBA, Weatherproof Amplified Speaker (VHF)		■	
69834-001	PCBA, Weatherproof Amplified Speaker (UHF)	■		■
BB133	Battery Back-up Kit	■	■	■
40201-010	Battery, 2.8 Ah, 12 V dc (included in BB133)	■	■	■
XB001	External Weatherproof Long-life Battery Kit	■	■	■
40201-008	Battery, 18 Ah, 12 V dc for XB001	■	■	■
SPK200	Solar Interface Kit	■	■	■
12506-001	Remote Volume Control L-Pad	■	■	■
RFP7784-108	Solar Panel	■	■	■
190-002PS	Weatherproof 15 V dc Power Supply Kit, 85-265 V ac, 50/60 Hz	■	■	■
40408-011	Battery Charger for 40201-008	■	■	■
51809-006	1A SloBlo Fuse	■	■	■

## Programming Software and Cable

Part No.	Description	13352	13362	13372
19101-024	RF Module Programming Kit (software & cable)		■	■
XAC1000A	CARD Suite Programming Software CD	■	■	■
XAC0004A	Programming Cable (for speaker)	■	■	■

## Performance Specifications

### Electronic

Output power.....	2 mW to 8 W (default 8 mW)
Sound pressure level .....	107 dB SPL, 1 watt at 1 meter
Nominal coverage when surface-mounted to wall (ref. -6 dB)	
Vertical .....	Upward: 40° Downward: 60°
Horizontal .....	90°
Model 13352 audio input level .....	20 to 1500 mVrms
Audio speaker volume adjustment .....	80-116 dB SPL
Audio speaker volume.....	Factory set @ nominal 86 dB SPL at a distance of 1 meter
Frequency response.....	450 Hz - 3000 Hz +/-5 dB

### Power Requirements

#### **Model BB133 Battery Back-up Kit**

Voltage.....	12 V dc
Capacity.....	2.8 Ah
Battery life	
Model 13372.....	120 minutes at full output
Model 13362.....	75 minutes at full output

#### **Model XB001 External Long-Life Battery Kit (with 40201-008 battery)**

Voltage.....	12 V dc
Capacity.....	18 Ah
Battery life	
Model 13372.....	15 hours at full output
Model 13362.....	12 hours at full output

#### Model 40404-060 External DC Power Source (Included in 190-002PS Kit)

Output voltage (adjustable).....	13.2–15.0 V dc (Set to 15.0 V for battery trickle charge)
Rated output current .....	2.1 amps
Rated output power.....	25 watts
Input voltage.....	85–264 V ac, 50–60 Hz
Input current.....	0.7 A/115 V ac, 0.4 A/230 V ac

#### **Solar panel output (at charge controller module)**

Voltage (trickle charge).....	12 V dc
-------------------------------	---------

**Mechanical**

Physical dimensions .....	8.02 × 8.12 × 9.52 inches
Enclosure material .....	Glass-reinforced polyester, 0.20 inch thick
Hardware.....	Urethane gaskets, stainless steel hardware
Color .....	Black
<b>Shipping weights</b>	
Model 13352 .....	6.6 lbs.
Model 13362 /13372 .....	7.3 lbs.

**Environmental**

Temperature range.....	-20° C to +60° C
Weatherproof rating.....	Rainproof
Humidity .....	95% non-condensing
RF Module (Models 13362 /13372 only)	

**General**

Frequency range .....	VHF: 154-174 MHz UHF: 450-470 MHz
Antenna impedance.....	50 Ω
Operating voltage.....	9-18 V dc, 12 V dc nominal
Decoder.....	CTCSS/CDCSS

**Receiver (measurement procedures made per ANSI/TIA/EIA-603)**

Sensitivity (12 dB SINAD) .....	0.25 μV
Inter-modulation .....	60 dB
Spurious response.....	55 dB
Audio output.....	700 mVrms, Vp-p 3.5 kHz deviated signal

**Approvals**

FCC Identifier .....	VHF: AIERT 17-142 UHF: AIERT 17-442
FCC Compliance .....	Part 90

**VHF Antenna**

Dimensions.....	Maximum 3.00 inches high
Mounting.....	BNC connector
Impedance .....	50 Ω

**UHF Antenna**

Dimensions.....	Maximum 3.00 inches high
Mounting.....	BNC connector
Impedance .....	50 Ω

## Introduction

The GAI-Tronics Model 13352, 13362 and 13372 Addressable Amplified Speaker Assemblies are designed for remote paging in temporary or permanent applications such as public gatherings, construction sites, or amusement parks.

Model 13352 accepts a 600-ohm, 0-dBm signal from a telephone page port or paging adapter using two telephone wire pairs: one pair for audio and the other for contact closure access. This configuration provides one-way paging using existing telephone wiring with local 12 V dc power.

Model 13362 and Model 13372 incorporate VHF and UHF (respectively) to provide wireless, one-way paging from a few feet to many miles away depending on the terrain, the antenna system, and the transmitting device.

These speakers can be added to an existing radio system with minimal cost or effort. With local 12 V dc or battery/solar power, reliable public address paging is possible from a portable, mobile, or base radio.

Each of the wireless speaker assemblies can be programmed for individual, group (zone), or system-wide access via DTMF or 2-Tone coding with up to eight different access codes. The volume of each speaker can be programmed via the XAC1000A CARD Suite software or controlled remotely via DTMF code. There are also termination provisions for a remote, hard-wired L-pad volume control. Each unit can be bench-programmed prior to installation, thus limiting field installation time.

All of the models can operate in a Generic or a Selective broadcast mode of operation through the use of a preprogrammed access code. In the Generic mode, the speaker assembly broadcasts all system communications received on the 600-ohm input or the programmed (licensed) RF frequency and PL code (if used). In the Selective mode, only communications preceded with the speaker's preprogrammed access codes are broadcast.

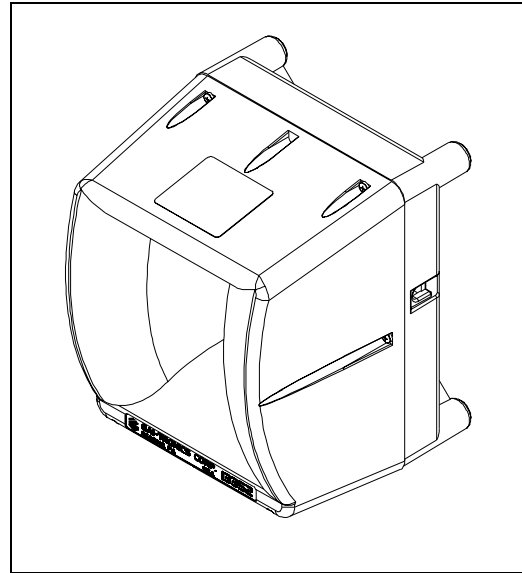

Figure 1. Addressable Amplified Speaker Assembly

## Functional Description

Each Addressable Amplified Speaker is capable of two different modes of operation; Generic Operation and Selective Operation.

### Generic Operation

While in the “off” state or sleep mode, the speaker assembly detects the presence of a page closure (Model 13352) or carrier-detect (Models 13362/13372) and becomes activated. Any audio that is being transmitted is now broadcast over the speaker while the page closure is present. After a preprogrammed amount of time after the page closure (Model 13352) or carrier-detect (Model 13362/13372) is no longer present, the speaker assembly returns to the “off” state. Each speaker is factory-programmed for this mode of operation (default).

**NOTE:** The speaker “on” state can be overridden by the shutdown closure input, which returns the unit to its “off” state. This can be used in areas where an all-page command is given but the speaker local to the page location is turned off to reduce feedback. The “shutdown” closure input could be from a handset hookswitch, relay, or other similar device. The speaker can be programmed via the XAC1000A CARD Suite software to provide receive capability at all times.

### Selective Operation

Selective Operation allows addressable access to each speaker using DTMF or 2-Tone signaling. Either “DTMF” or “2-Tone” must be selected via the CARD Suite programming software.

While in the “off” state, the speaker assembly detects the presence of a page closure (Model 13352) or carrier-detect (Models 13362/13372) and becomes activated. The speaker assembly waits for the preprogrammed code to enable the speaker amplifier. If the correct code is detected, the speaker assembly determines if it is an audio message or an audio level adjustment command.

- If it is an audio message, the speaker assembly is energized and the audio is transmitted to the speaker output.
- If it is an audio level adjustment command, the speaker assembly is energized and a test tone is transmitted to the speaker output. After a preprogrammed amount of time without the page closure (Model 13352) or carrier-detect (Model 13362/13372) being present, the assembly returns to sleep mode.

During either DTMF or 2-Tone operation, the speaker assembly recognizes one to eight codes that can be used for unit activation. The first code is used for individual paging, and is the only code used for remote volume adjustments (DTMF only). Any of the other seven codes can be used for zone or all paging functionality.

### DTMF Signaling

In this operating mode, the speaker assembly detects preprogrammed DTMF tones in this operating mode. The protocol for the DTMF symbol stream during this operation is the programmed digit length (1-8 digits) followed by a “#” DTMF symbol. **The DTMF symbol stream cannot include the “\*” or “#” in its identification string.** The DTMF code is programmed via the CARD Suite software application. If the code is blank, the unit will not have this operating functionality.

## 2-Tone Signaling

In this operating mode, the speaker assembly detects preprogrammed 2-Tone signaling codes. The 2-Tone protocol is one frequency followed by a second frequency, and is programmed via the CARD Suite software application. If the 2-Tone code is blank, the unit will not have this operating functionality.

## Volume Adjustments

The speaker assembly volume can be adjusted by two methods: remote volume adjustment and optional local volume adjustment. The default volume level is programmed through the CARD Suite software package.

### Remote Volume Adjustment

The remote volume adjustment is performed through the use of DTMF control only. The speaker receives the volume level from the DTMF signal and delivers a 1-kHz signal to the speaker output corresponding to the volume level defined. The PTT or page closure of the transmitting device (radio, remote controller, etc.) must be activated during the volume adjustment process.

The protocol for initiating remote volume control is: the speaker's individual identification access code, followed by a "\*" to activate the unit, and then an "\*" to enter the test tone mode.

After the "\*", a test tone is generated for a time period that is preprogrammed via Card Suite. During the test tone, the volume level can be changed by increasing or decreasing the setting by one step. Press "\*" to increase or "#" to decrease, without entering the assembly identification code.

If the unit receives another DTMF code that is not "\*" or "#" (or no input) during the test tone, the assembly stores the last volume level in memory and returns to sleep mode. This stored level is used as a reference for incoming audio signals and the appropriate gain required in the automatic gain control (AGC) circuit for stable output volume level.

### Local Volume Adjustment

Local Volume Adjustment is available through the use of an L-pad connected to the speaker output (Model 12506-001). No test tone is generated during this adjustment, and the user must generate audio for this test while adjusting the L-pad.

This is a passive adjustment. The maximum output level is defined by the CARD Suite program or by Remote Volume Adjustment. The Local Volume Adjustment can only adjust the output level lower than the maximum programmed level.

## Field Installed Options

### Model SPK200 Solar Interface Kit

The Model SPK200 Solar Interface Kit provides battery recharging when an external power source is not available. This option is supplied with a terminal block, battery charge regulator module, Solar mounting bracket, wiring harness, and the necessary mounting hardware for the components. This option provides a complete solar charging system when purchased with the GAI-Tronics Model RFP7784-108 Solar Panel. Refer to Publication 43003-039 for solar panel installation details. This kit must be used in conjunction with the XB001 External Long-Life Battery Kit and the 40201-008 18 Ah battery.

### Model XB001 External Long-Life Battery Kit

The XB001 External Long-Life Battery Kit includes a NEMA 4 weatherproof enclosure with battery mounting bracket, a sealed 12 V dc external receptacle, and mating speaker power connection cable. The required Model 40201-008 18 Ah battery is purchased separately.

This kit allows the Addressable Amplified Speaker to be installed within two feet of the weatherproof enclosure for true battery-powered operation. Combining this kit with the Model SPK200 Solar Panel Interface Kit and Model RFP7784-108 Solar Panel will provide a completely wireless operation. If the application is only temporary, the speaker can easily be “unplugged” from the battery enclosure and relocated or stored. Refer to Publication 43003-037 for installation details.

## Model 190-002PS Power Supply Kit

The Model 190-002PS Power Supply Kit is designed for mounting to the bottom of a CB193-xxx or CB194-xxx RF Call Box. The kit includes a 2-gang weatherproof electrical box, 15 V dc power supply, mounting bracket, 3-inch pipe nipple, ½-inch NPT conduit hub, tamper-resistant hardware, and security bit (T15 Torx).

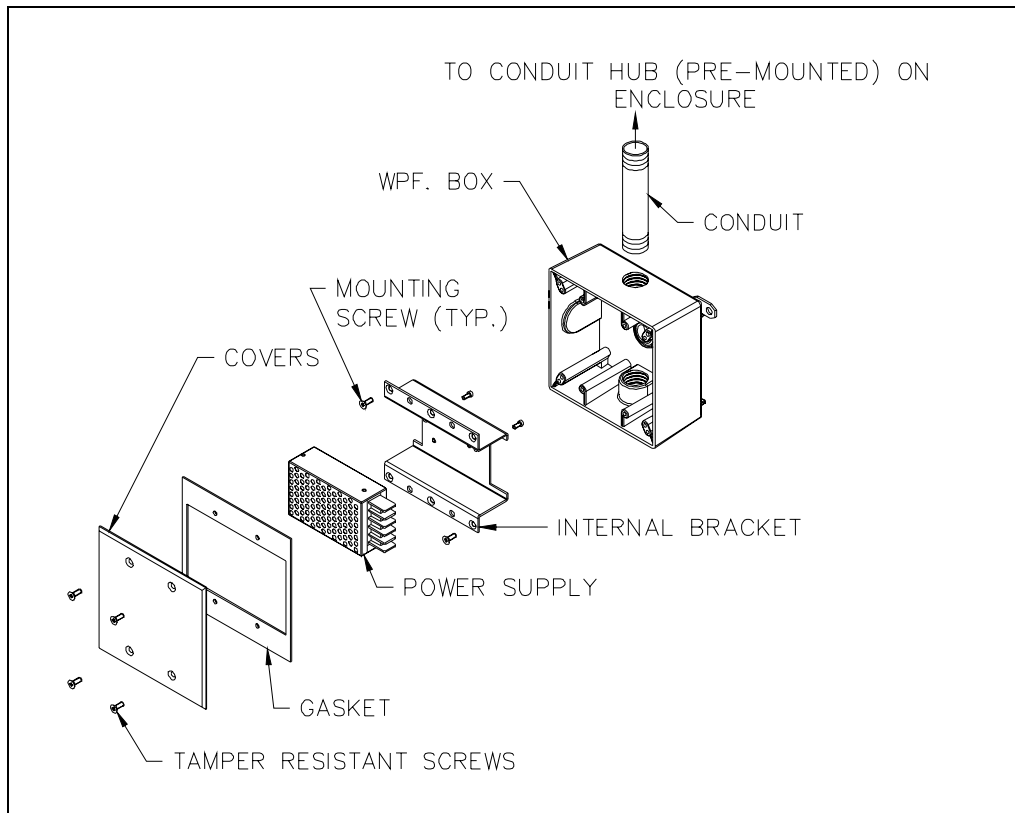

Figure 2. Model 190-002PS Power Supply Kit Components

To properly charge the back-up battery (if required), the 40404-060 power supply (included in the kit) must be set for 15.0 V dc output. This output can be adjusted at the voltage adjustment potentiometer labeled ADJ. Refer to Figure 2 for wire connections.

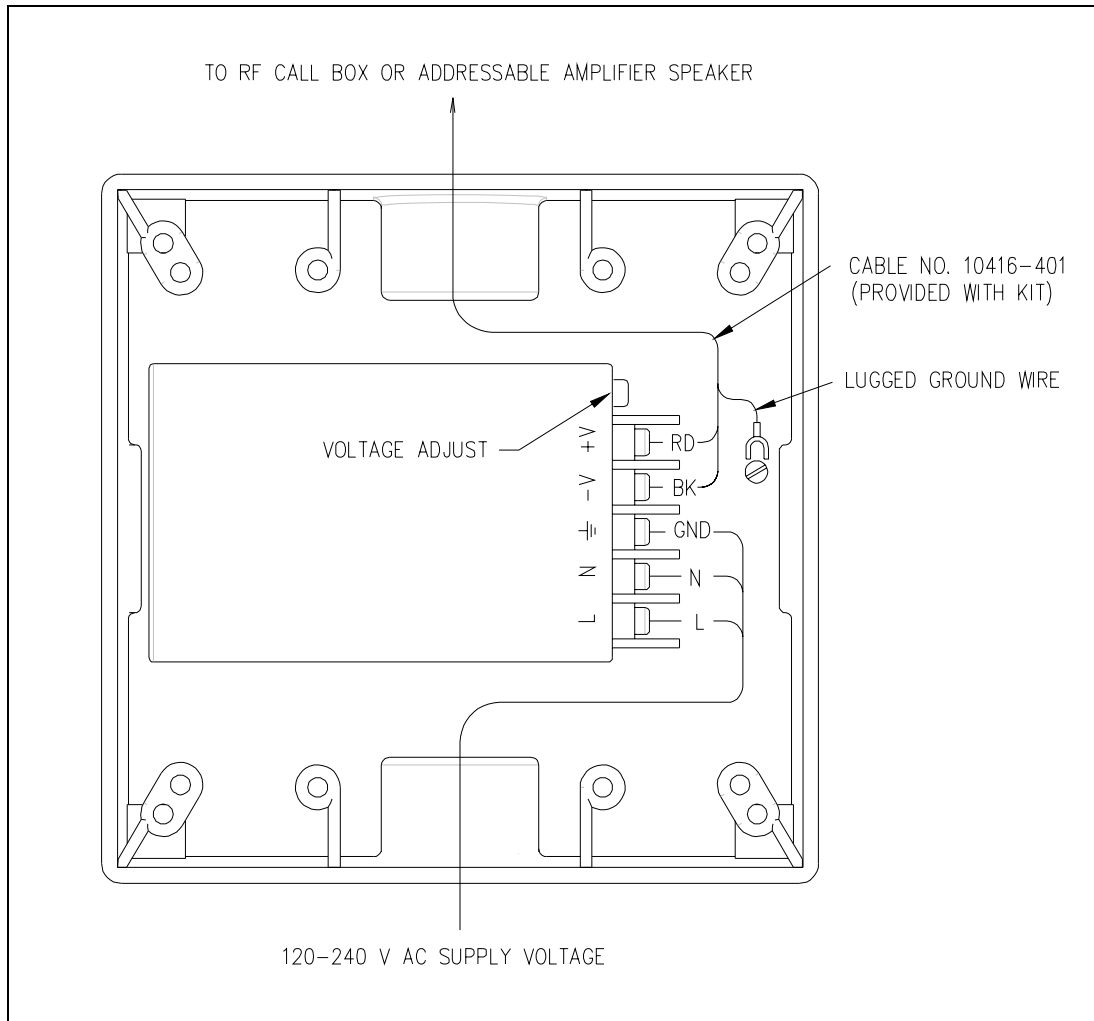

Figure 3. Power Supply Wiring Connections

## Model BB133 Battery Back-up Kit

The Model BB133 Battery Back-up Kit provides up to 2 hours of continuous output (full power) if main power is lost or disconnected. The kit includes a bracket, Model 40201-010 2.8 Ah battery, and a single mounting screw. Refer to Publication 43003-036 for installation details.

## Model 12506-001 Remote Volume Control Assembly

The Model 12506-001 Remote Volume Control Assembly allows local, mechanical control of the speaker's output volume. As previously stated, this is a passive adjustment. In this application, the maximum output level is defined by the CARD Suite program. The Local Volume Adjustment can only adjust the output level lower than the maximum programmed level.

## PC Programming

All Addressable Amplified Speakers require the use of the XAC1000A CARD Suite programming software application and the XAC0004A Programming Cable for the speaker for non-default settings. The programmable settings are Volume Control, Generic or Selective Operation, and Activation Code entry.

Models 13362 and 13372 RF speakers additionally require the use of the 19101-024 RF Module Programming Kit. This kit includes a separate cable and software for programming the RF Module's operating frequency and TPL/DPL code. Refer to the programming instructions on page 22 of this manual.

# Operation

## Use Cases

### Generic Broadcast Activation

Step	Action	Response
1	Page closure (Model 13352) or carrier-detect (Model 13362/13372) is detected.	Speaker assembly activates and waits for audio signal.
2	Audio is present.	The speaker assembly routes the audio signal through AGC to the speaker amplifier at a constant signal level.
3	Page closure (Model 13352) or carrier-detect (Model 13362/13372) is de-activated.	The speaker assembly disables the speaker amplifier and returns to sleep mode after a predetermined amount of time.

### Selective Broadcast Activation

Step	Action	Response
1	Page closure (Model 13352) or carrier-detect (Model 13362/13372) is detected.	The speaker assembly activates and waits for correct Page ID.
2	Correct Page ID is received.	The speaker assembly enables speaker amplifier and waits for audio signal.
3	Audio is present.	The speaker assembly routes audio signal through AGC to speaker amplifier at a constant signal level.
4	Page closure (Model 13352) or carrier-detect (Model 13362/13372) is de-activated.	The speaker assembly disables the speaker amplifier and returns to sleep mode after a predetermined amount of time.

## Remote Volume Adjustment (DTMF only)

Step	Action	Response
1	Page closure (Model 13352) or carrier-detect (Model 13362/13372) is detected.	The speaker assembly activates and waits for correct Page ID.
2	The correct Page ID and audio setting is received.	The speaker assembly enables the speaker amplifier, generates a tone for received audio setting that is broadcast over the speaker for a preprogrammed amount of time.
3	Another audio setting is received.	The speaker assembly generates another tone for the new audio setting that is broadcast over the output for a preprogrammed amount of time.
4	Page closure (Model 13352) or carrier-detect (Model 13362/13372) is de-activated.	The speaker assembly disables the speaker amplifier, stores the last output level setting, and returns to sleep mode.

## Selective Broadcast Operation, Wrong Activation Code Received

Step	Action	Response
1	Page closure (Model 13352) or carrier-detect (Model 13362/13372) is detected.	The speaker assembly wakes up and waits for correct Page ID.
2	An incorrect Page ID is received.	The speaker assembly returns to sleep mode after a preprogrammed amount of time.

# Installation

## Mechanical Receipt Inspection

The Addressable Amplified Speaker is shipped in a cardboard container, protected from movement and distress by a self-forming packaging material. Thoroughly inspect it as soon as possible after delivery. In-transit damage should be immediately reported to the transportation company.

## Equipment Required

### Programming

- PC with Windows 95 or newer operating system.
- **NOTE: CARD Suite is not compatible with Windows NT.**
- XAC1000A Programming Software (all models)
- XAC0004A Programming Cable (all models)
- 19101-024 RF Programming Kit (Models 13362 and 13372 only)

### Tools

- #1 Phillips screwdriver
- 1/16-inch flat blade screwdriver (for remote volume control connection only)

## Cable Installation Safety Considerations

Interconnecting, communications, and Class 2 dc power cables should be separated from electrical light or other Class I circuits by at least 2 inches. The exception is where Class I wiring or power circuits are run in a raceway, or are metal-sheathed or metal-clad, or are permanently separated from the conductors of the other circuitry by a continuous and firmly fixed nonconductor such as porcelain tubes or flexible tubing in addition to the insulation on the wire. Communications cables and in-building wiring should be listed and marked for the purpose according to NEC Article 800.

## Mounting

1. Untwist the two nylon ties used for wire management. Unplug the quick-connect fastons from the speaker and unplug the 11-point connector from the PCBA. The front section can now be completely separated from the rear section. See Figure 4.
2. Mount the rear section to any flat surface using 1/4-inch customer-provided screws in each of the four 0.280-inch mounting holes in the corners of the rear section. Refer to Figure 4 for mounting hole pattern dimensions. A Model 231 Pole Mounting Kit can also be used for pole or surface mounting. Two customer-provided mounting screws are required to surface mount this kit. The kit includes four mounting screws needed to secure the speaker to the kit's bracket.

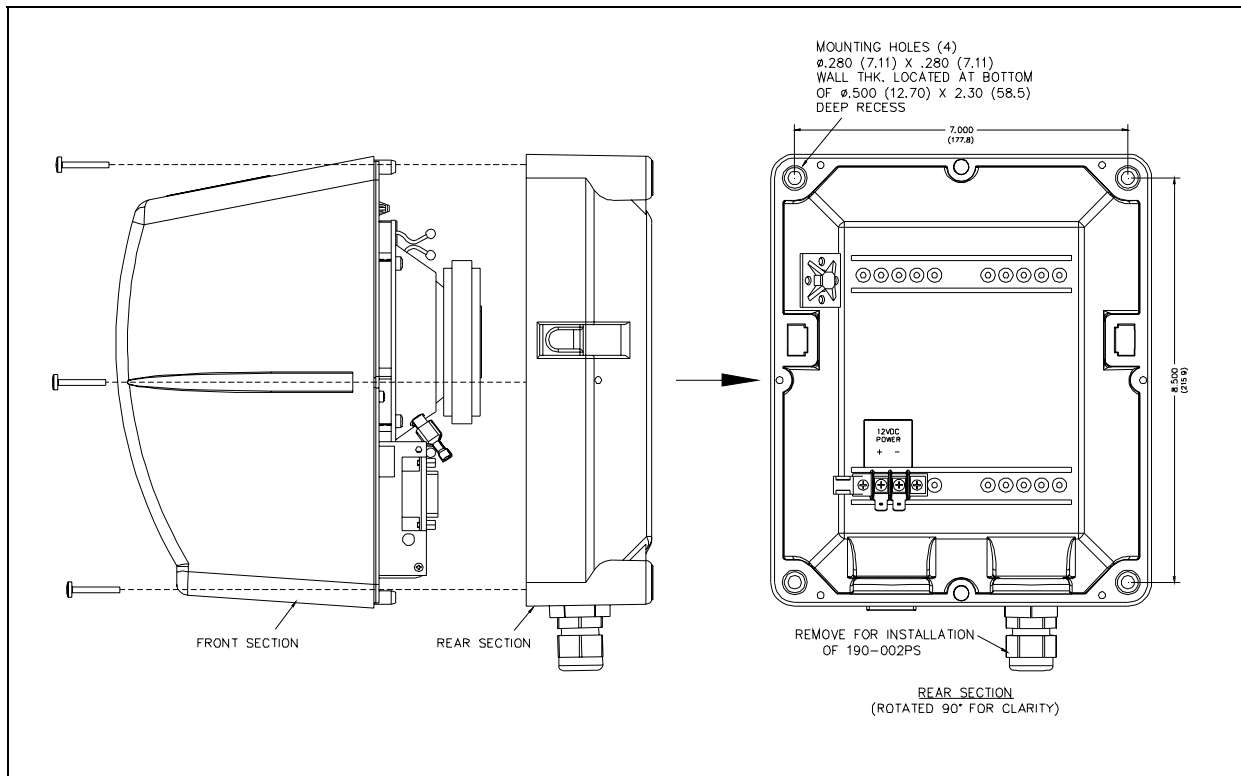

Figure 4. Mounting Detail

## Programming

### General Description

GAI-Tronics' CARD Suite Programming Software, Part No. XAC1000A, is needed to program some of the functions and parameter settings of the Addressable Amplified Speaker. It allows entry of operational programming data into your personal computer for transfer to the equipment. The programmed data can be retrieved, edited, archived, and printed in hard copy for record keeping.

The Model 19101-024 RF Module Programming Kit is needed to program the licensed frequency and associated TPL/DPL code into the radio.

### CARD Suite Software Installation

The minimum system requirement necessary to support the CARD Suite Software Application is Windows 95 or newer. However, CARD Suite is not compatible with Windows NT. The CARD Suite Programming Application components are contained on CD-ROM. Please exit all other programs that are running until the installation is complete.

Place the CD in the PC's CD-ROM drive. If the "auto-run" feature on your CD-ROM drive is enabled, the CARD Suite menu screen should appear within a few seconds. If for any reason the installation does not start up automatically, it can be run from the Start menu. Select the **START** button and then select **Run** from the Start menu. At the prompt, type **x:\Setup.exe** where **x** represents the drive letter that is associated with your CD-ROM drive. A CARD Suite icon should appear on the desktop display after successful installation.

### RF Module Programming Software Installation

The Model 19101-024 RF Module Programming Kit includes a software CD, two cable assemblies, and a 9-25 pin adapter. The software (labeled DTXL-PCPS-2.0) also requires Windows 95 or newer to operate. Insert Disk 1 into the PC's A:/ drive, and select the ".exe" file. The program will tell you when to insert Disk 2.

### Preparing to Program

Remove the speaker from the carton and position on a flat surface with the front of the speaker facing up. Although the front section attaches to the rear section with six Phillips screws, only two screws have been secured during the production process. Back out the two screws on the left and right side of the speaker. All screws are captive and will remain in the front section. Lift the front section straight up and flip to the left-hand side of the rear section. Refer to Figure 8 and Figure 9.

## Programming the Addressable Speaker PCBA (All Models)

The Addressable Amplified Speaker must be connected to your personal computer with the programming cable, part number XAC0004A, before the CARD Suite programming software can be used. To make this connection, attach the cable to the COM1 or COM2 connector on the computer. Proceed with programming as follows:

1. Connect 12 V dc power from a charged battery or external power supply to the terminal strip located on the rear section of the speaker assembly.
2. Plug the other end of the programming cable into RS232 programming connector J1. Verify that the LED illuminates (indicating proper connection).
3. The unit can now be accessed. From the XAC1000A CARD Suite software application, the user can perform the following functions: “Read Unit” (F2), “Program Unit” (F8), or perform the “COM Port Test” (CTRL+T).
4. Insert the CD-ROM into your computer. If the Auto Play function does not launch the installer, open the disk from the My Computer icon and double click on the set up icon.

## Settings and Adjustments

The following settings and adjustments are made via the XAC1000A CARD Suite programming software:

### **Mode:**

- Generic (default)
- Selective

### **Coding:**

- DTMF (default)
  - Code (1-8 digits)
  - Alias (12 characters maximum)
- 2-Tone
  - A Tone duration (0.5 to 4.0 seconds, 0.5-second intervals)
  - B Tone duration (0.5 to 4.0 seconds, 0.5-second intervals)
  - A Tone, 400 to 2700 Hz, 0.1-Hz increments
  - B Tone, 400 to 2700 Hz, 0.1-Hz increments
  - Alias (12 characters maximum)

**Standby Time:** 0.5 to 12 seconds, 0.5-second intervals (default - 3 seconds)

**Speaker Volume:** 2 mW to 8 W (default 16 mW); 80 dB to 116 dB (default 89 dB)

**Test Tone Length** Initial tone, 1 to 6 seconds, 0.5 second intervals (default – 3 seconds)  
Following tones, 1 to 6 seconds, 0.5 second intervals (default - 3 seconds)

Refer to the CARD Suite Help (F1 or Help menu item) for further information on setting these parameters.

## Programming the RF Module (19101-024 Programming Kit) - Models 13362/13372 Only

1. Disconnect the connecting cable from the RF Module. Refer to Figure 4.
2. Connect the DTXP-PAC cable assembly's red and black leads to a 12 V dc source (battery or supply) and plug into the 15-pin D connector on the RF Module.
3. Connect one end of the 9/RTC-PAS programming cable to the PC's serial port and the other (modular) end to the modular receptacle on the DTXP-PAC cable.
4. Proceed with programming following instructions provided with the kit and the software help files.  
**Program only the frequency and PL information into the RF Module.**

Wiring

Each of the speaker assemblies is designed for bottom cable entry, where two 3/4-inch conduit entries are located. Field wiring can enter the speaker housing using the installed 3/4-inch NPT cable bushing (bottom right), or with rigid or flexible conduit by removing the installed bushing. The 3/4-inch male conduit plug (bottom left) can be removed for additional conduit connections. Refer to Figure 5. When conduit entries are closed and sealed, the speaker is completely rain-tight.

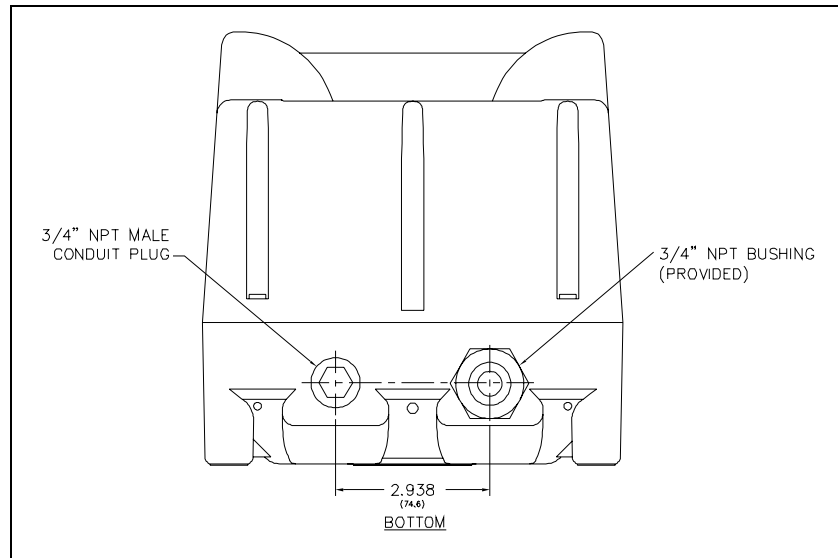

Figure 5. Bottom view of speaker assembly

Install the necessary cable for wiring the speaker. Two pairs are required for wiring to the audio input terminals for the Model 13352 unit only (one audio, one page closure). Two conductors are required for supplying external 12 V dc power to all three models of the speaker. A minimum 22 AWG-conductor is recommended for audio and page control and a minimum 20 AWG-conductor is recommended for 12 V dc power.

The unit requires 12 V dc for operation, which can be supplied through the use of an external power supply, Model 40404-048. The Model XB001 External Battery Kit or the internal Model BB133 Battery Backup Kit are also available for provided a 12 V dc source. Refer to the installation instructions that accompany these GAI-Tronics kits for more information.

**NOTE: For Model 13352 only** - The audio pair and page control conductors should be connected in parallel between all controlled speakers as indicated in Figure 6 below.

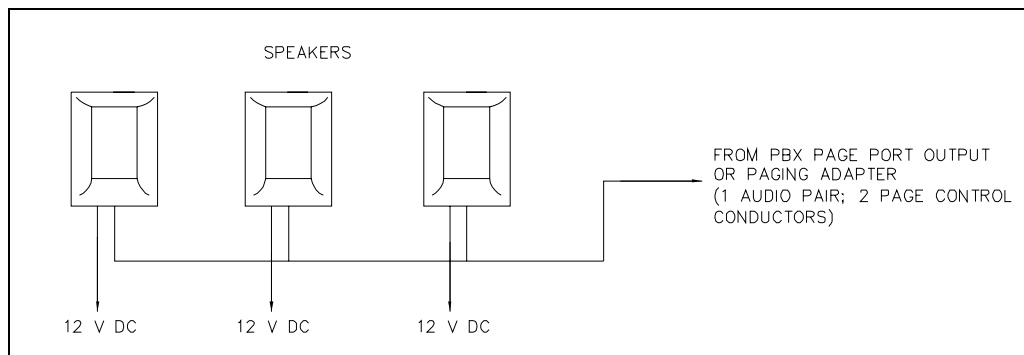

Figure 6.

## 12506-001 Remote Volume Control Wiring Instructions

If the speaker requires local mechanical control of the output volume, an 8-ohm L-Pad volume control (Part No. 12506-001) can be installed. The 12506-001 Remote Volume Control assembly is designed for indoor installation but can easily be installed in a single gang outlet box, mounted inside a weatherproof enclosure. Note that for full output volume range, the amplified speaker should be programmed for full audio output power. Figure 7 below shows the wiring configuration needed for the use of the L-Pad connection for local volume adjustment.

Refer to Figure 8 or Figure 9 to locate TB1, the 11-point connector noted in the Figure 7. The connector numbering begins with position 1 at the bottom and ends with position 11 at the top.

1. Open the speaker housing.
2. Remove the white wire from TB1-8 and reroute the wire to TB1-7.
3. Connect the yellow wire from L-Pad to TB1-8.
4. Connect the orange wire from L-Pad to TB1-7.
5. Connect the black wire from L-Pad to TB1-6.

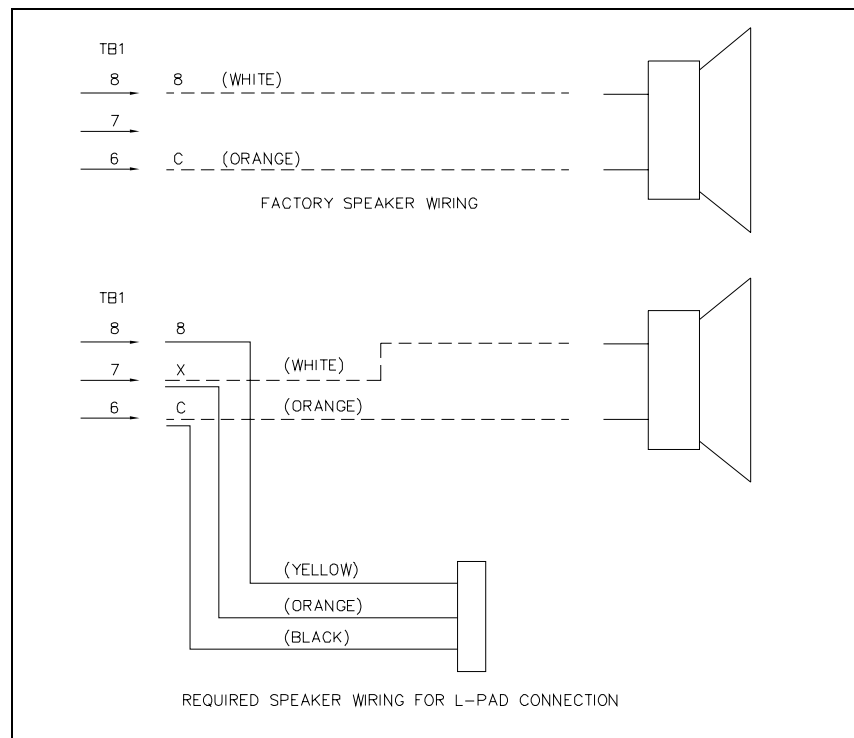

Figure 7.

With the rear section securely mounted and field wiring in place, reattach the wiring harness' quick-connect fastons to the speaker. Reconnect the 11-point connector to the PCBA and route the wires through both nylon ties. Re-twist the nylon ties to secure the wires. Refer to Figure 8 and Figure 9 for wire routing. Assemble the speaker sections and tighten front panel screws to 16 to 20 in-lbs. of torque.

**NOTE: Be careful not to pinch wiring between the front and rear speaker sections when securing them together.**

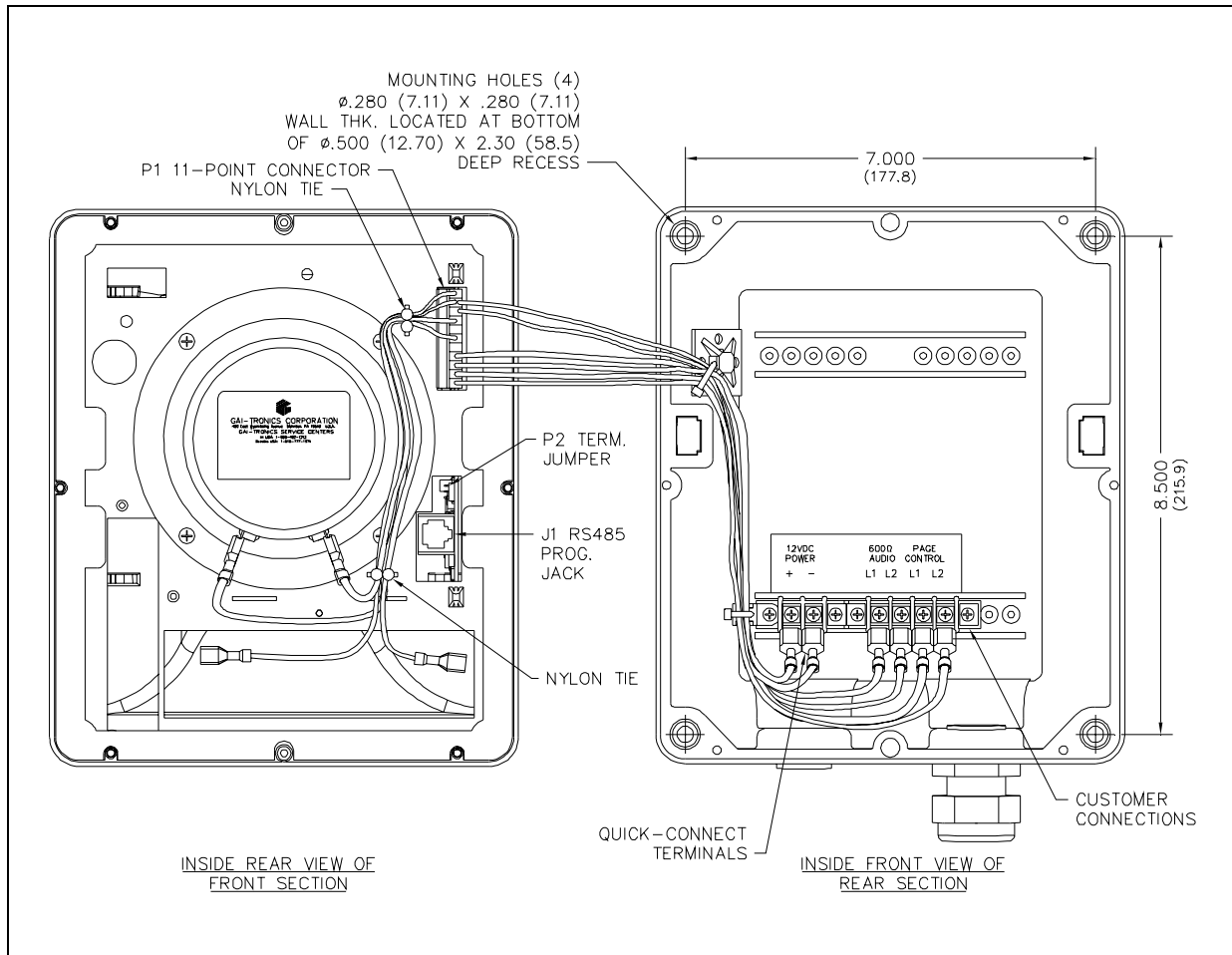

Figure 8. Model 13352 Weatherproof Amplified Speaker Assembly

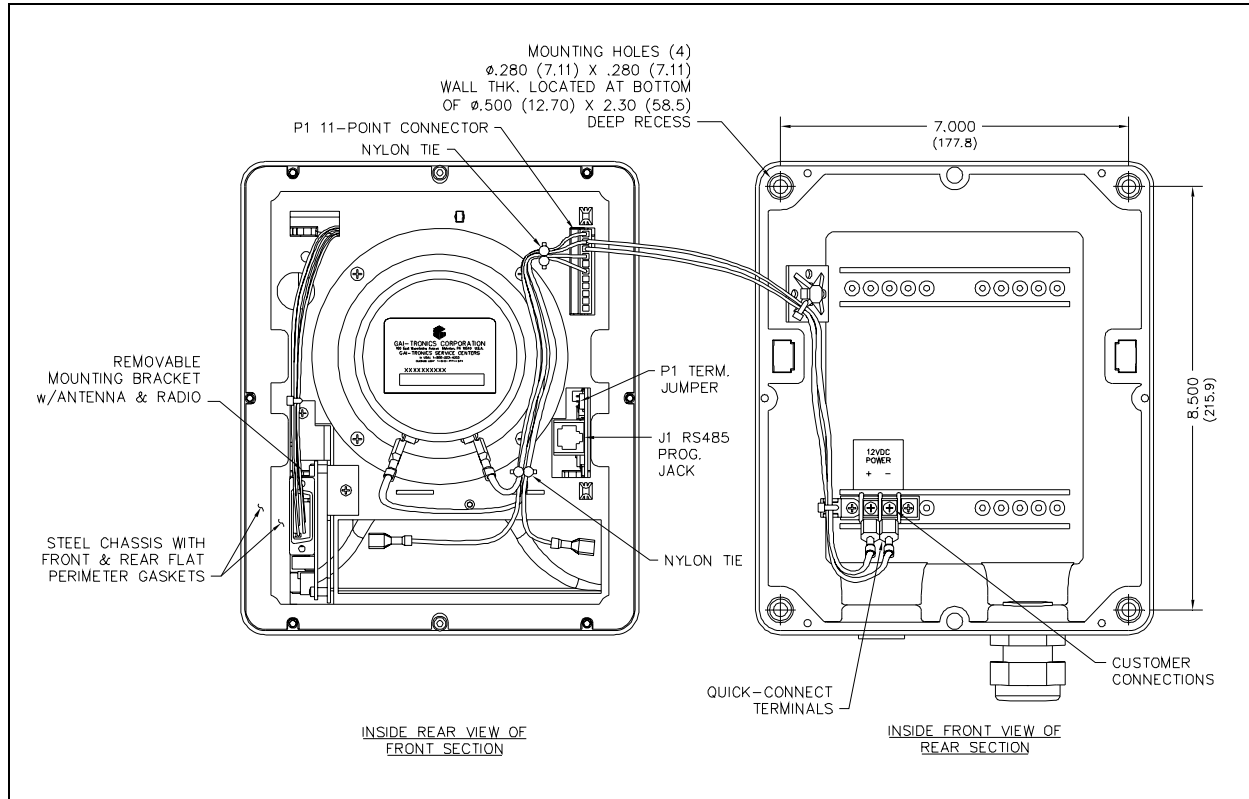

Figure 9. Model 13362 and 13372 Weatherproof Amplified Speaker Assemblies

# Hardware Configuration

## Jumpers

The Model 13352 P2 termination jumper setting configures the unit for 600-ohm (P2-2 to P2-3) or 15 k-ohm (P2-1 to P2-2) termination. For Models 13362 and 13372, this jumper has no function. This jumper is accessible by separating the rear section of the speaker from the front section. Refer to Figure 10.

## Fuse Replacement



Replace with Littelfuse (1 amp) 5 × 20 mm 239 001 or CooperBussman (1 amp) 5 × 20 mm GMC-1 fuses only.

There are two fuses located on the PCBA. Fuse F1 is the external power fuse, which limits the current draw from the external power supply. Fuse F2 is the battery fuse, which limits the current draw from the battery. Refer to Figure 10.

## LEDs

Two indicator LEDs are located on the PCBA, but are visible only on the speaker's front section when the assembly is opened. The power supply LED is activated when the unit is receiving external power. The programming LED indicates when CARD Suite programming has been initiated.

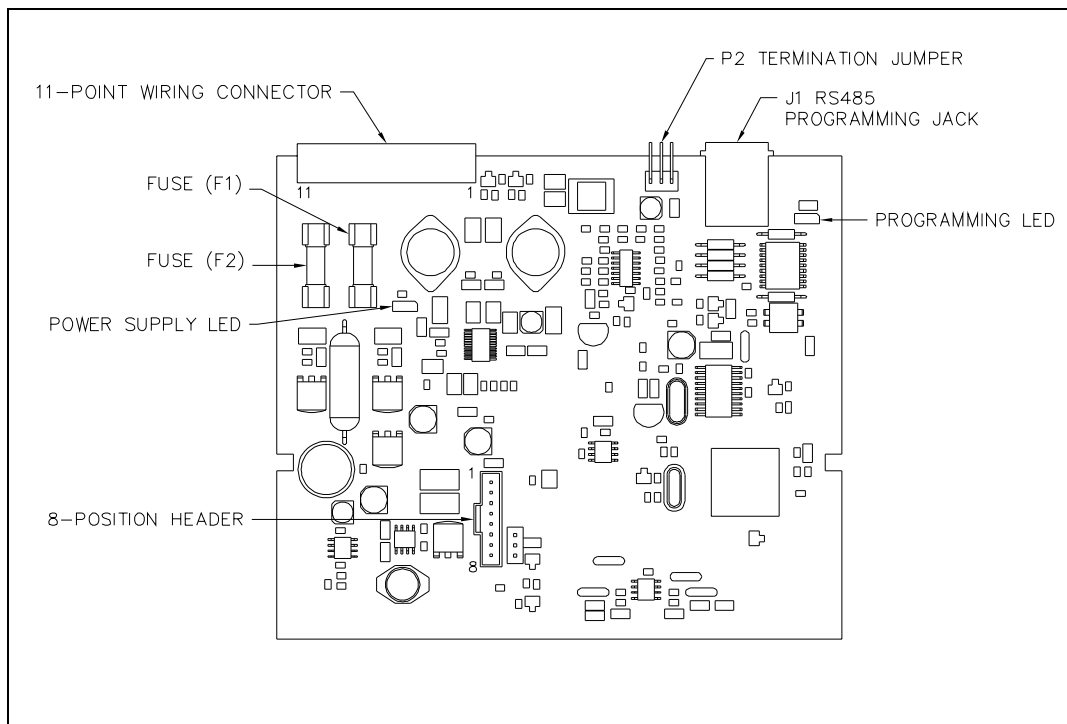

Figure 10. Amplified Speaker Assembly PCBA (Models 69834 and 69840)

## TB1 Wiring Connector

The pin-out for the 11-point wiring connector on the speaker half of the assembly is described below. The numbering orientation is shown in Figure 10.

Pin No.	Pin Name	Function
1	600Ω AUDIO L1	Positive audio input for 13352; no connection for Models 13362 or 13372
2	600Ω AUDIO L2	Negative audio input for 13352; no connection for Models 13362 or 13372
3	PAGE CONTROL L1	Active low signal to initiate speaker for 13352; no connection for Models 13362 or 13372
4	PAGE CONTROL L2	Ground reference for PAGE CONTROL L1 or SHDN
5	SHDN	Active low signal to shut down speaker for 13352; no connection for Models 13362 or 13372
6	C	Negative connection to speaker output
7	X	Common connection for speaker output used in conjunction with L-Pad
8	8	Positive connection to speaker output
9	12 VDC +	External power source
10	12 VDC -	Ground reference for external power source or internal battery
11	BAT	Internal battery

Radio Connector Pinout

The pin-out for the radio connector on the speaker half of the assembly is described below. The numbering orientation is shown in Figure 10.

**Addressable Amplified Speaker’s Radio Connector Pin-Out**

Position DB15 Connector	Position 8-Pin Connector	Color	Radio Reference
Pin 1			
Pin 2			
Pin 3			
Pin 4			
Pin 5			
Pin 6	Pin 5	Black	Power
Pin 7			
Pin 8			
Pin 9			
Pin 10			
Pin 11			
Pin 12	Pin 2	Black	Audio
Pin 13	Pin 6	Black	Carrier detect
Pin 14			
Pin 15	Pin 4	Black	Ground

## Terminal Strip Designations

The wiring terminal strip is located on the rear half of the assembly. The screw terminal designations for the Model 13352 are as shown below. Refer also to Figure 8.

Terminal No.	Label	Function
1	12 VDC +	External power source
2	12 VDC -	Ground
3	600 $\Omega$ AUDIO L1	Positive audio input
4	600 $\Omega$ AUDIO L2	Negative audio input
5	PAGE CONTROL L1	Active low signal to initiate speaker assembly
6	PAGE CONTROL L2	Ground reference of PAGE CONTROL L1.

The screw terminal designations for the Model 13362 and 13372 are shown below. Refer also to Figure 9.

Terminal No.	Label	Function
1	12 VDC +	External power source
2	12 VDC -	Ground

## Definitions and Acronyms

Term	Definition
<b>CSQ</b>	Carrier squelch
<b>TPL</b>	<b>Tone Private Line</b> - A means of grouping users of a common radio channel. Subaudible tones are transmitted with audio; a particular radio's speaker (or the speakers of a group of radios) will unmute to broadcast a transmission only if the associated subaudible tone identifies it as belonging to the radio's user group.
<b>DPL</b>	A system analogous to TPL but using low speed digital signaling instead of subaudible tones.
<b>dBm</b>	A measurement of decibels per meter (sound pressure level).
<b>Ah</b>	<b>Ampere-hour</b> is the unit quantity of electricity carried past any circuit point in one hour by a steady current of one ampere.