



GAI-TRONICS® CORPORATION
A HUBBELL COMPANY

Model 295F and 295W Clean Phone™ Telephone

Confidentiality Notice

This manual is provided solely as an operational, installation, and maintenance guide and contains sensitive business and technical information that is confidential and proprietary to GAI-Tronics. GAI-Tronics retains all intellectual property and other rights in or to the information contained herein, and such information may only be used in connection with the operation of your GAI-Tronics product or system. This manual may not be disclosed in any form, in whole or in part, directly or indirectly, to any third party.

General Information

The GAI-Tronics Model 295F Flush-Mount and Model 295W Wall-Mount Clean Phone™ Telephones are designed for the exacting requirements of clean rooms. They are constructed of stainless steel and have a completely smooth polyester front panel that will not trap particulate matter. Calls are made by pressing one of the two auto-dial buttons or by using the fully functional keypad. The Flash button allows the phone to use the features of a PBX system. The oversized, clearly labeled buttons allow for easy operation with gloved hands.

Auto-Dial Buttons

The Model 295 Clean Phones feature two auto-dial buttons to store frequently dialed telephone numbers. If using the auto-dial feature, it is important to program the Auto-dial Time Delay option, which sets the amount of time lapse between the auto-dial button press and the actual dialing operation. The default time period of ten seconds could be too long if the feature is to be used for emergency communication. This feature is fully explained in the Programming Information section.

Auto-Answer

The Model 295 also offers a programmable activation/deactivation of the Auto-answer feature. When activated, this feature determines how many rings must elapse before auto-answering. The Auto-answer feature allows the telephone to go off-hook automatically so technicians do not have to leave their work stations to answer the telephone.

A light under the ON portion of the ON/OFF button is activated to indicate if the telephone is off-hook. If the Auto-answer feature is not activated, the telephone will not go off hook until someone actually touches the ON/OFF button.

Local or Remote Programming

The Model 295 can be programmed locally or remotely using another DTMF telephone. The programming mode, whether local or remote, must be entered through a series of button presses.

NOTE: The local programming password is factory-programmed as **# 1 2 3** and cannot be changed. The remote password is factory-programmed as **0 2 9 5**, but can be changed to any four-digit number using the programming instructions provided.

Model 295 can also be programmed to use either a long (350 ms) or short (50 ms) called-party loop current disconnect mode. Determine your system configuration before completing this sequence.

Touch-Tone or Pulse Dialing

The Model 295 can be programmed for touch-tone (also known as dual-tone multifrequency [DTMF]) or pulse dialing. To determine what kind of dialing you require, contact your local telephone company.

Safety Guidelines

When installing any GAI-Tronics telephone equipment, please adhere to the following guidelines to ensure the safety of all personnel:

- NEVER install telephone wiring during a lightning storm.
- NEVER install telephone jacks in wet locations unless the jack is specifically designed for wet locations.
- NEVER touch uninsulated telephone wires or terminals unless the telephone line has been disconnected at the network interface.
- USE CAUTION when installing or modifying telephone lines.

If you have any questions, please call our toll-free number: 800-492-1212

Installation

Feedback problems can be avoided by installing each clean telephone in a separate room and wall.

Model 295F Mounting and Wiring

1. Refer to Figure 6 on page 17 for a drilling template.
2. Use the template dimensions as a guide to mark the wall, and make the required cuts.
3. Place the back bracket in the wall. Locate the mounting holes.
4. Drill two holes in the lower right corner and the upper left corner, to secure the bracket. Drill the rest of the holes you intend to use, and secure the remaining holes.
5. Feed the wiring through the supplied bushing.
6. Snap the cover off of the modular wall jack. Refer to Figure 1 as a wiring guide. Wire the incoming tip wire to the green wire of the modular jack. Wire the incoming ring wire to the red wire of the modular jack, the (COM) wire to the yellow wire of the modular jack, and (-48 V) wire to the black wire of the modular jack.

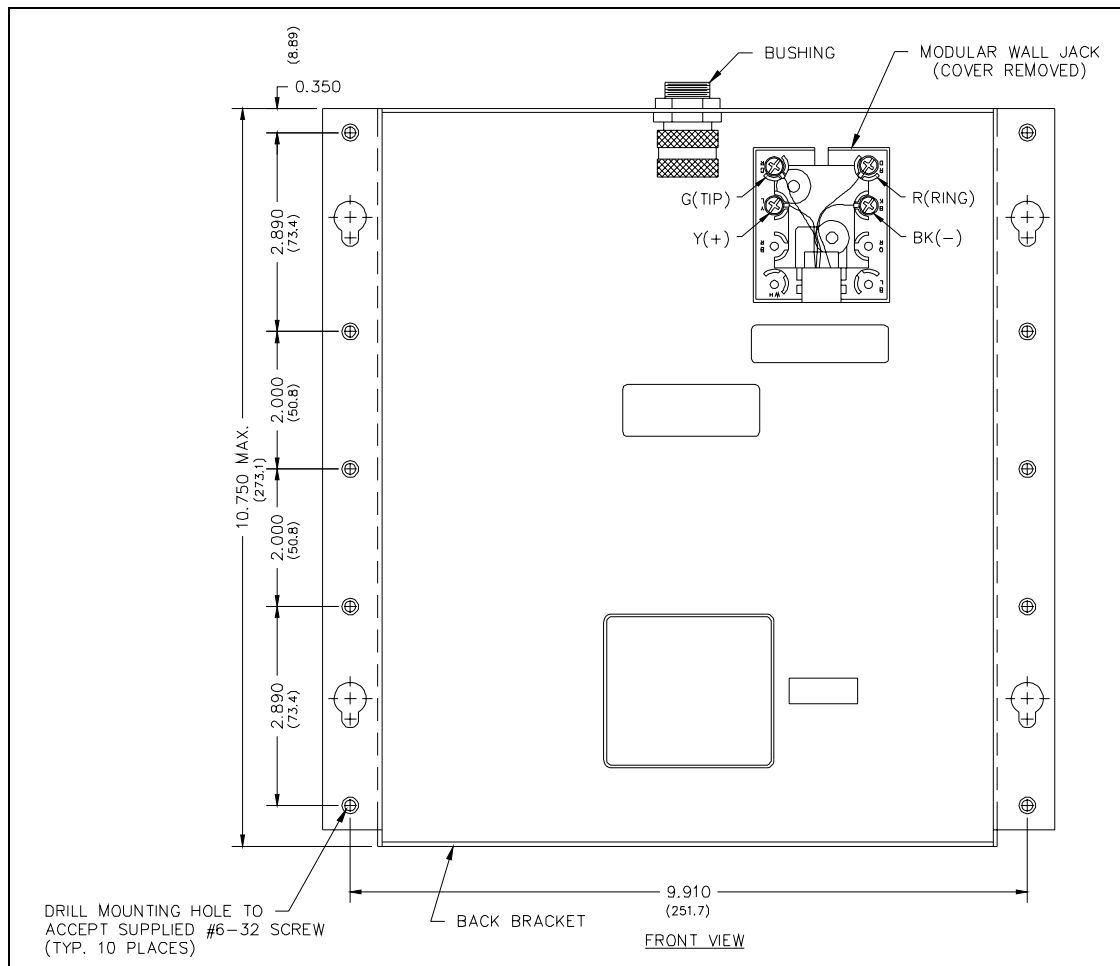

Figure 1. Modular Wall Jack Wiring for Model 295F

7. Replace the modular jack cover. Plug the modular connector from the front panel assembly into the modular wall jack. Take the front panel of the clean telephone and align it with four slots in the mounting bracket.
8. Using the pressure points shown in Figure 2, push the panel firmly in and then down.

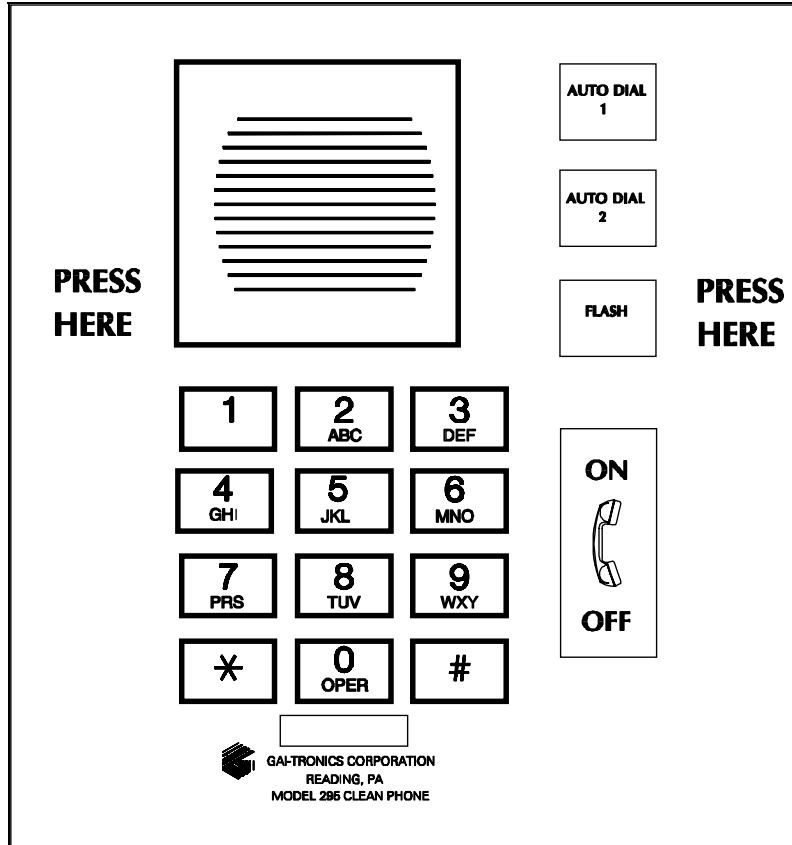

Figure 2. Front panel with pressure points shown

Model 295W Mounting and Wiring

1. Position the back box on the wall, making sure the box is level. Drill the two corner holes in the upper left and lower right, and secure it with the screws.
2. Drill the remaining holes, and secure the remaining screws.
3. Feed the wires through the bushing.
4. Snap the cover off the modular wall jack. Refer to Figure 3. Wire the incoming tip wire to the green wire in the modular jack, the incoming ring wire to the red wire in the modular jack, the (COM) wire to the yellow wire, and the (-48 V) wire to the black wire. **DO NOT REMOVE** the blue and white wires. Replace the modular wall jack cover.
5. Plug the modular connector from the front panel assembly into the modular wall jack.
6. Take the front panel of the clean telephone and align it with the four slots in the mounting bracket.
7. Using the pressure point shown in Figure 2, push the panel firmly in and then down.

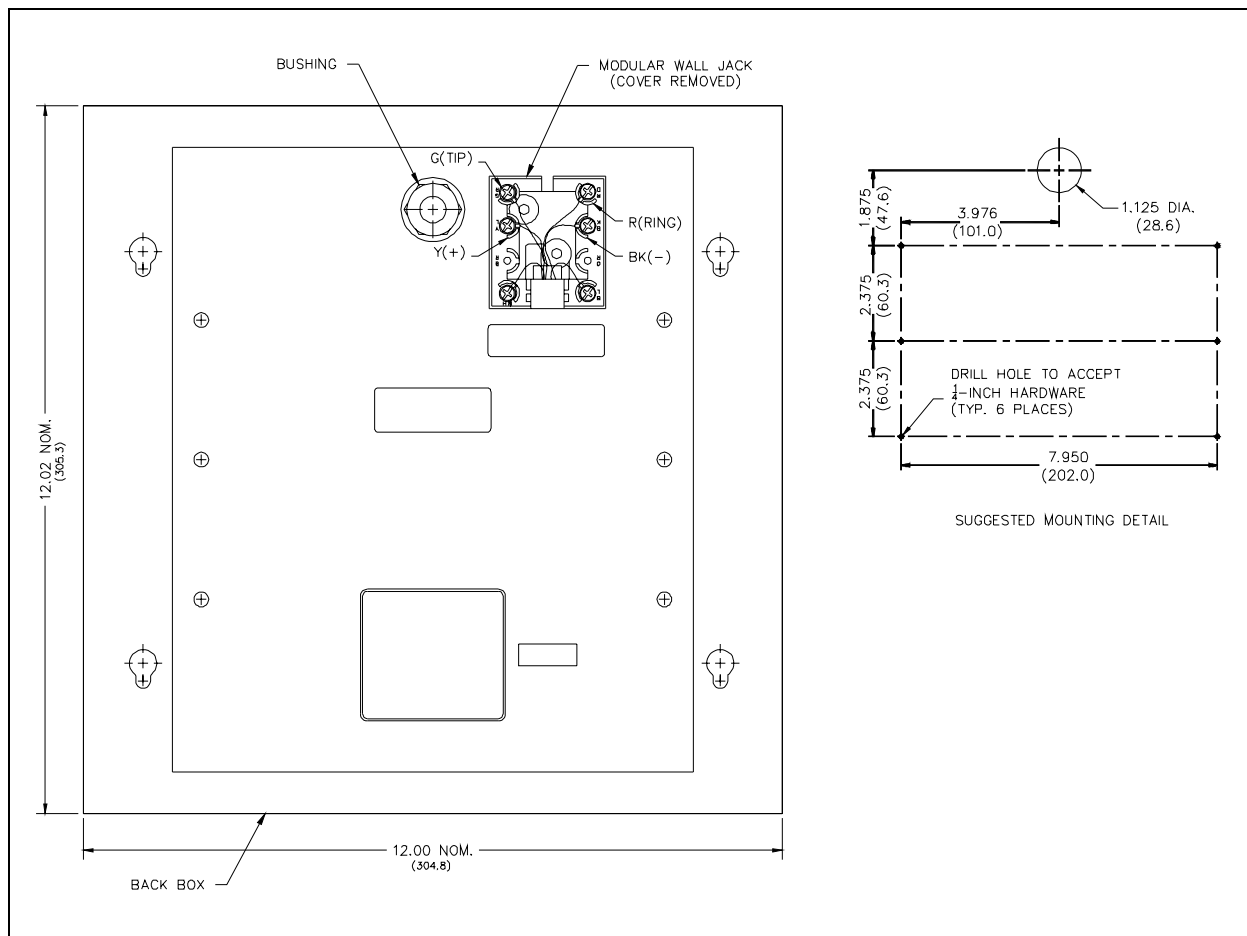

Figure 3. Mounting the Model 295W

Power and Wiring Information (Level C Power)

The Model 295F and 295W Clean Phones are powered from a 48 V dc @ 250 mA power supply. The power supply should be Nationally-Recognized Testing Laboratory (NRTL) listed per UL specification UL 1012 or equivalent.

If these clean telephones are powered through the black and yellow “spare pair” in the telephone cable, the power to these wires must be limited to UL Level C power. To meet the requirements for Level C power, the current to the telephone must be limited to 1 ampere maximum at 48 V dc.

The GAI-Tronics Model 237 Power Supply is a 48 V dc @ 250 mA UL listed power supply that can be used to power a single Model 295 Clean Phone. See Figure 4 for wiring details for the Model 237 Power Supply.

The distance between a telephone and the 48 V dc power source is limited only by the maximum allowable wire resistance, (32 ohms). See the table for calculated distances for standard wire sizes.

Calculated Distance for Standard Wire Sizes			
AWG	Feet	Meters	Miles
24	620	190	0.11
22	985	300	0.18
20	1585	480	0.30
19	1985	605	0.37
18	2500	760	0.47
16	3980	1210	0.75
14	6350	1935	1.2

Refer to the table provided above. When using 24 AWG wire, the 48 V dc power source can be located up to 620 feet, 190 meters, or 0.11 miles away from the phone. Paralleling pairs of the same gauge wire will increase operating distance by a factor of two.

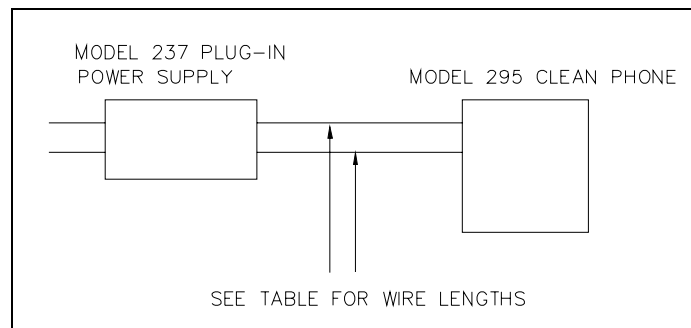

Figure 4. Model 237 Power Supply Wiring

Microphone Sensitivity and Speaker Volume Adjustment

The speaker volume and microphone sensitivity controls are factory-set to a nominal value. This value may not be suitable for the particular noise environment where Model 295 phone is to be installed. To obtain the best performance possible in your particular area, we recommend that the following adjustment procedure be performed after Model 295 is installed in its final location and in typical ambient noise conditions. You will need a small standard screwdriver for the adjustments.

1. Remove the unit from its wall mounting, but do not unplug it.
2. Call someone, or have someone call you from a handset type telephone. They should be outside your location and should read a few paragraphs of text.
3. See Figure 5. While they are reading, locate the **MIC** adjustment on the rear of the unit, and turn it counterclockwise until it is all the way down.
4. Locate the **SPEAKER** adjustment. Turn it until the speaker volume is set to a level that the person talking can be comfortably understood when you are a few feet from the telephone.
5. Turn the **MIC** adjustment clockwise until the speaker starts to “cut out” the speech from the person talking—when it sounds like the first syllable of every word is missing.
6. Back the **MIC** adjustment off until the speech comes back to normal but no farther. This adjustment should require only an eighth to a quarter turn in the counter-clockwise direction.
7. Try a test conversation on the line. If the quality of communication is unsatisfactory, begin with Step 1 of this section, and readjust Model 295.

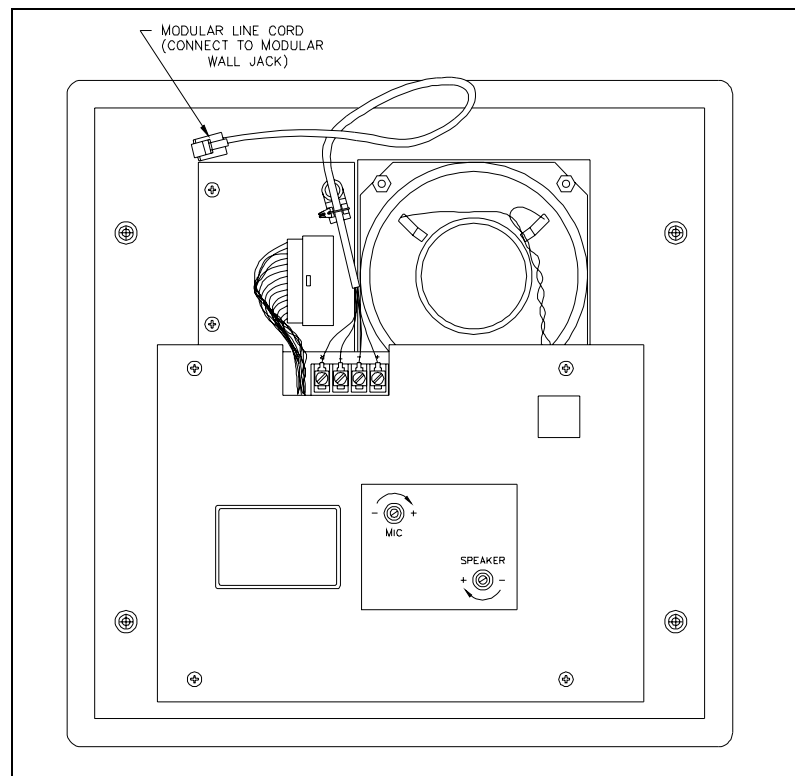

Figure 5. Microphone and Speaker Adjustments

Model 295 is now fully adjusted for the acoustics and noise conditions within your area.

Programming Information

The GAI-Tronics Model 295 Clean Phone is programmable. There are a number of features that can be customized, or you may use the factory settings (defaults).

The programmable features include setting the auto-dial numbers, setting the auto-dial time delay, setting the number of rings before Model 295 automatically answers, selecting DTMF or pulse dialing, and selecting the remote programming password.

Model 295 Clean Phone can be programmed in two ways—local and remote. The front panel of the Model 295 Clean Phone is used for local programming with the local password. To program the unit remotely, you must call the Model 295 Clean Phone, and enter the password (from a DTMF phone).

Programming the unit is the same whether the programming mode is entered locally or remotely except that each mode has its own unique password. The unit must be in the programming mode before attempting to program any functions. After each programming key sequence, either a confirmation tone (a single beep) or an error tone (a high-low tone) will sound. A confirmation tone indicates the command was accepted, and that the new input has been saved. Any *fully completed* programming sequence is saved in the permanent memory. If, however, you begin programming a function, and do not complete all the steps, *it will not be saved*, and all the information for that function must be re-entered.

The Programming Table lists the programmable functions on the Model 295 Clean Phone and the input codes for each of these functions. The table also lists the defaults (factory settings).

Local Programming

Entering the Local Programming Mode

To program the Model 295 Clean Phone locally, you must enter the local programming password, which is fixed and cannot be changed. Enter the key sequence **# 1 2 3** to access the local programming mode. The unit will emit a high pitch beep for each correct key pressed. The light under the front panel ON/OFF button will begin blinking at a slow rate to indicate the programming mode has been entered. If an incorrect key is pressed, you will hear a single low pitch beep to warn that the password is incorrect.

Following the correct entry of the local programming password, the unit is in a programming mode where the user may program the unit as desired. For programming instructions, see the Programming Table.

Each digit of the local programming password must be entered within 5 seconds of the one before it. If a digit is not entered within the 5-second limit, the unit will emit a single low pitch beep and exit the local programming mode. If the unit times out waiting for the password, or if the password entered incorrectly, the unit will automatically exit the local programming mode.

The unit will ignore any incoming calls when in the local programming mode.

Exiting the Local Programming Mode

There are two ways to exit the local program mode:

- If there is no keypad activity for 20 seconds, the unit automatically exits the local program mode.
- The user can terminate the mode at any time by pressing the ON/OFF button.
- The unit will emit a short low pitch beep and turn off the light under the ON/OFF button

Remote Programming

Entering the Remote Programming Mode

Using a DTMF telephone, dial the unit's telephone number, wait for an answer tone, and enter the unit's password. If you have not changed the password, enter **0 2 9 5**. The password provides two benefits—first, it allows Model 295 to be programmed from any DTMF telephone, and second, permits only authorized personnel (those informed of the password) to reprogram the unit. If there is a security leak, the password can be updated in a matter of seconds. The password can be changed through local or remote programming.

The unit will answer the call (following the programmed number of rings), then send a short tone (answer tone). The password must be entered within two seconds of hearing the answer tone. The remote programming mode can only be entered when the entire password has been entered in the allotted time. The unit will immediately hang up (disconnect) if the password is entered incorrectly. Failure to begin entering the password after the answer tone will result in an intercom call.

The front panel light under the ON button will blink slowly, indicating that the unit is in the programming mode. All front panel keys and incoming calls are ignored during the remote programming mode.

Exiting the Remote Programming Mode

There are three ways to exit the remote programming mode:

- The unit detects the caller has hung up.
- The caller enters * for at least two seconds.
- The unit times out waiting for a digit (20 seconds).

In any event, the unit will go on-hook and extinguish the light under the ON button.

Programming Instructions

Before you begin programming, determine whether you will be programming locally or remotely. This way, you can clear on the steps you will take and the passwords you will need to complete the programming.

Programming Table			
Function	Key Sequence	Description	Default Settings
Reset the unit to the factory codes (Defaults)	#00	Resets the unit to the codes programmed at the GAI-Tronics factory.	<ul style="list-style-type: none"> • No auto-dial 1 number; • No auto-dial 2 number; • Auto-answer after 3 rings; • Remote password 0 2 9 5; • DTMF dialing; • Dial-tone disconnect disabled
Input the telephone numbers for one or both auto-dial buttons	<i>DD... *N</i>	<p>Assigns a user-supplied telephone number to either auto-dial button. <i>DD...</i> represents the user-supplied telephone number, which can be up to 16 digits in length. <i>N</i> represents the desired auto-dial button number (1 or 2).</p> <p>To store * or #, enter the digits twice in succession. To force the unit to wait for a second dial tone, enter *# in the appropriate place in the dialing sequence.</p> <p><i>For Example:</i> To assign the police emergency number 911 to Auto-dial 1, enter 911*1.</p> <p>If you must dial 9 to get an outside line, using the above example, enter 9*#911*1.</p>	No numbers
Set the auto-dial delay time	#100 <i>N</i>	<p>The auto-dial delay time is the amount of time the unit waits before dialing the programmed telephone number for the auto-dial feature.</p> <p>Available time delay options are 2 through 9 seconds.</p> <p>NOTE: A three-second auto-dial delay time is recommended. <i>For Example:</i> For a three-second auto-dial delay time, enter #1003.</p>	10 seconds

Programming Table			
Function	Key Sequence	Description	Default Settings
Store the unit's remote programming password	#14DDDD	This password must be supplied to remotely program Model 295. The length is four digits. <i>For Example:</i> To program the password 1234, enter #141234 .	0 2 9 5
Set the auto-answer feature	#15D	Programs Model 295 to automatically answer after <i>D</i> rings, where <i>D</i> is a DTMF digit from 1 to 9. To deactivate the auto-answer mode, so that the telephone must be manually answered, enter 0 . Model 295 will sound a "telephone ring" on the speaker to announce an incoming call. <i>For Example:</i> To set the unit to auto-answer after 5 rings, enter #155 . To deactivate the Auto-answer feature, where the ON button on the telephone must be pressed to answer the call, enter #150 .	3
Store the dialing mode	#20L	This option selects either DTMF or pulse dialing mode. To dial using DTMF, <i>L</i> = 1. To dial using pulse mode, <i>L</i> = 0. To program DTMF, enter #201 . To program pulse, enter #200 .	1 (DTMF)
Store the called-party loop current disconnect mode	#21L	This option selects either of the two loop current disconnect periods for a call to Model 295. Determine your system configuration before completing this sequence. To program the long disconnect, <i>L</i> = 1. To program the short disconnect, <i>L</i> = 0. To program the long disconnect, enter #211 . To program the short disconnect, enter #210 .	1 (Long)

Operating Instructions

Incoming Calls

The clean telephone can be programmed to operate in two different modes: auto-answer and conventional answer.

To answer an incoming call at a clean telephone programmed to operate conventionally, press the ON/OFF button on the front panel of the telephone. The indicator light will go on when the call has been successfully connected. Press the ON/OFF button to disconnect and end the conversation.

To answer an incoming call at a clean telephone programmed to operate in the auto-answer mode, do nothing. The telephone will automatically answer the call after the programmed number of rings. The call will then be connected, and conversation can take place as normal. Once the line is established, the indicator light on the front panel will light. The telephone line can be disconnected several different ways. See the Programming Information section for details on call termination.

Outgoing Calls

To place a call from the clean telephone, simply press the ON/OFF button on the front panel, and dial the desired number. The call is connected as with any conventional telephone. To disconnect the call, press the ON/OFF button.

When programming and/or making test calls to emergency numbers, remain on the line, and briefly explain to the dispatcher the reason for the call. Perform such activities in the off-peak hours, such as early morning or late evenings.

Conversing

The clean telephone is designed to operate in a variety of environments with different noise levels. The speaker volume and microphone sensitivity are set as part of the installation procedure. Depending on the level settings of these two parameters, the ideal distance from which to speak into the clean telephone may vary. The person speaking into the telephone should stand approximately 3 feet from the unit although the distance can vary and should be determined through trial and error in your setting.

In general, it is not advisable to yell or talk loudly when speaking through the clean telephone. The design of the unit takes background noise into consideration. Only in the loudest environments will it be necessary to speak in a louder voice. In most situations, yelling will only degrade the quality of your conversation.

User Instructions

Federal Communication Commission (FCC) regulations require that these guidelines be followed:

This equipment complies with Part 68 of the FCC Rules. On the rear of the unit is a label that contains, among other information, the FCC Registration Number and Ringer Equivalence Number (REN) for this equipment. If requested, this information must be given to the telephone company.

The REN is used to determine the quantity of devices that may be connected to the telephone line. Excessive RENs on the telephone line may result in devices not ringing in response to an incoming call. In most, but not all areas, the sum of the RENs should not exceed five (5.0). To be certain of the number of devices that may be connected to the line, contact the telephone company to find out the maximum RENs for the calling area.

If your telephone equipment causes harm to the telephone network, the telephone company may discontinue service temporarily. If possible, they will notify you in advance. If advance notice is not practical, you will be notified as soon as possible. You will be informed of your right to file a complaint with the FCC.

The telephone company may make changes in its facilities, equipment, operations, or procedures that could affect the operation of the equipment. If this happens, the telephone company will provide advance notice for you to make the necessary modifications to maintain uninterrupted service.

If trouble is experienced with this equipment, please contact GAI-Tronics at 800-492-1212 inside the USA or 610-777-1374 outside the USA, for repair and/or warranty information. If the trouble is causing harm to the telephone network, the telephone company may request you remove the equipment from the network until the problem is resolved.

This equipment uses the RJ11C USOC jack.

This equipment cannot be used on telephone company-provided coin service. Connection to party-line service is subject to state tariffs.

Specifications

Power input 48 V dc, 250 mA
 USOC RJ11C
 Signaling DTMF or pulse (programmable)
 FCC Registration Number ADGUSA-60747-MT-E
 Ringer Equivalence Number (REN)..... 0.4B
 Speaker output..... 85 dBA spl @ 1 meter, full volume (max. speech level)
 Operating temperature -20° C to +60° C (-4° F to +140° F)

Model 295F

Construction Front panel: tactile, polyester membrane panel
 Mounting bracket: 16-gauge stainless steel

Dimensions Front panel: 12 W × 12 H inches; (304.8 × 304.8 mm)
 Mounting bracket: 10.75 W × 10.875 H × 1.75 D inches; (273.1 × 276.2 × 44.3 mm)

Weight..... 5.25 lbs

Model 295W

Construction Front panel: tactile, polyester membrane panel
 Mounting bracket: 16-gauge stainless steel

Dimensions Front panel: 12 W × 12 H inches (304.8 × 304.8 mm)
 Back enclosure: 12 W × 12 H × 2.06 D inches (304.8 × 304.8 × 52.3 mm)

Weight..... 5.25 lbs

Replacement Parts

The following list details the replacement parts available for the Model 295 Clean Phone. Please use reference number when ordering.

Part Number	Description
12518-002	PCBA Replacement Kit
12575-001	Front Panel Replacement Kit
12585-001	Speaker Assembly Kit
14560-002	Mounting Bracket (Model 295F only)
14560-005	Rear Enclosure (Model 295W only)

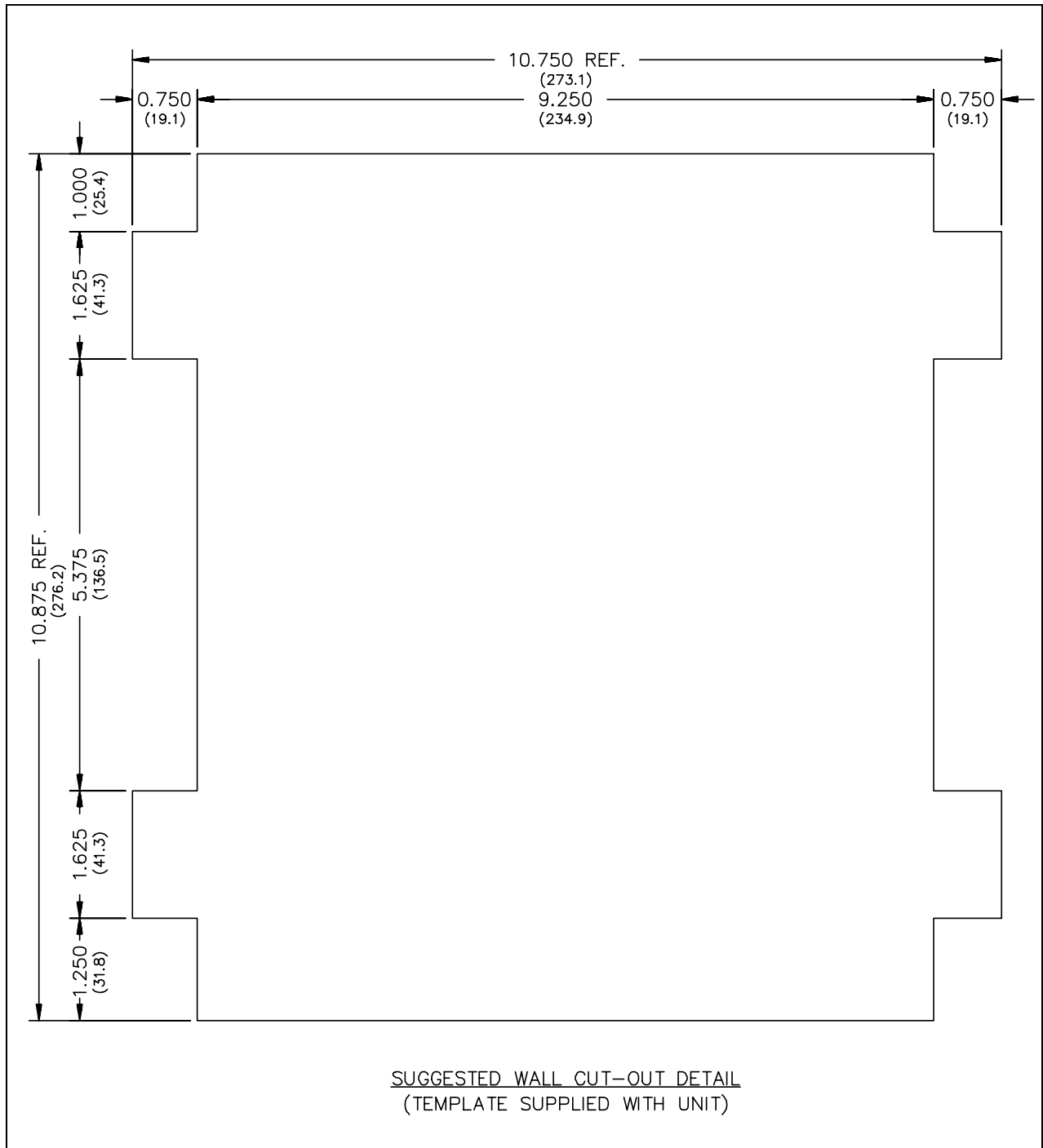

Figure 6. Drilling Template

Warranty

Equipment. GAI-Tronics warrants for a period of one (1) year from the date of shipment, that any GAI-Tronics equipment supplied hereunder shall be free of defects in material and workmanship, shall comply with the then-current product specifications and product literature, and if applicable, shall be fit for the purpose specified in the agreed-upon quotation or proposal document. If (a) Seller's goods prove to be defective in workmanship and/or material under normal and proper usage, or unfit for the purpose specified and agreed upon, and (b) Buyer's claim is made within the warranty period set forth above, Buyer may return such goods to GAI-Tronics' nearest depot repair facility, freight prepaid, at which time they will be repaired or replaced, at Seller's option, without charge to Buyer. Repair or replacement shall be Buyer's sole and exclusive remedy. The warranty period on any repaired or replacement equipment shall be the greater of the ninety (90) day repair warranty or one (1) year from the date the original equipment was shipped. In no event shall GAI-Tronics warranty obligations with respect to equipment exceed 100% of the total cost of the equipment supplied hereunder. Buyer may also be entitled to the manufacturer's warranty on any third-party goods supplied by GAI-Tronics hereunder. The applicability of any such third-party warranty will be determined by GAI-Tronics.

Services. Any services GAI-Tronics provides hereunder, whether directly or through subcontractors, shall be performed in accordance with the standard of care with which such services are normally provided in the industry. If the services fail to meet the applicable industry standard, GAI-Tronics will re-perform such services at no cost to buyer to correct said deficiency to Company's satisfaction provided any and all issues are identified prior to the demobilization of the Contractor's personnel from the work site. Re-performance of services shall be Buyer's sole and exclusive remedy, and in no event shall GAI-Tronics warranty obligations with respect to services exceed 100% of the total cost of the services provided hereunder.

Warranty Periods. Every claim by Buyer alleging a defect in the goods and/or services provided hereunder shall be deemed waived unless such claim is made in writing within the applicable warranty periods as set forth above. Provided, however, that if the defect complained of is latent and not discoverable within the above warranty periods, every claim arising on account of such latent defect shall be deemed waived unless it is made in writing within a reasonable time after such latent defect is or should have been discovered by Buyer.

Limitations / Exclusions. The warranties herein shall not apply to, and GAI-Tronics shall not be responsible for, any damage to the goods or failure of the services supplied hereunder, to the extent caused by Buyer's neglect, failure to follow operational and maintenance procedures provided with the equipment, or the use of technicians not specifically authorized by GAI-Tronics to maintain or service the equipment. **THE WARRANTIES AND REMEDIES CONTAINED HEREIN ARE IN LIEU OF AND EXCLUDE ALL OTHER WARRANTIES AND REMEDIES, WHETHER EXPRESS OR IMPLIED BY OPERATION OF LAW OR OTHERWISE, INCLUDING ANY WARRANTIES OF MERCHANTABILITY OR FITNESS FOR A PARTICULAR PURPOSE.**

Return Policy

If the equipment requires service, contact your Regional Service Center for a return authorization number (RA#). Equipment should be shipped prepaid to GAI-Tronics with a return authorization number and a purchase order number. If the equipment is under warranty, repairs or a replacement will be made in accordance with the warranty policy set forth above. Please include a written explanation of all defects to assist our technicians in their troubleshooting efforts.

Call 800-492-1212 (inside the USA) or 610-777-1374 (outside the USA) for help identifying the Regional Service Center closest to you.